

# User's Guide

– for use without a computer –



## Introduction

Important Safety Instructions .....	3
Copyright Notice.....	4



## Guide to Parts and Control Panel Functions

Parts .....	5
Control Panel Functions .....	6



## Handling Paper

Selecting Paper .....	8
Loading Paper.....	8



## Copying

Placing Originals on the Document Table .....	10
Copying Documents .....	11
Copying Photos.....	11
Speeding Up Copying.....	11



## Printing from a Memory Card

Handling a Memory Card .....	12
Selecting and Printing Photos Using an Index Sheet.....	14
Printing All Photos or DPOF Photos .....	15



## Printing from a Digital Camera

Digital Camera Requirements .....	16
Connecting and Printing.....	16



## Maintenance





Replacing Ink Cartridges.....	17
Checking and Cleaning the Print Head .....	20
Aligning the Print Head.....	20
Cleaning This Product .....	21
Transporting This Product.....	21

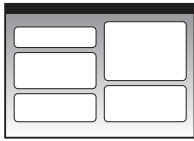
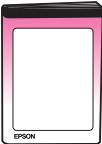

## Solving Problems

Error Indicators.....	22
Problems and Solutions .....	24
Contacting Customer Support .....	26

# Where to Find Information

Paper manuals	
	<b>Start Here</b> <p>Be sure to read this sheet first. This sheet tells you how to set up the product and install the software. It also includes instructions on loading paper and placing originals.</p>
(this book) 	<b>User's Guide -for use without a computer-</b> <p>This book contains information on how to use the product without connecting your computer, such as instructions on copying and printing from a memory card.</p> <p>If you have problems using the product, see the Solving Problems chapter in this book.</p>
Online manuals	
	<b>User's Guide</b> <p>This guide provides instructions for printing and scanning from your computer and information on the software.</p> <p>This guide is included on the software CD-ROM and installed automatically when you installed the software. To read this guide, double-click the icon on your desktop.</p>
 	<b>Online help</b> <p>Online help is built in each application included on the software CD-ROM. It provides detailed information on the application.</p>

# Introduction

## Important Safety Instructions

Before using this product, read and follow these safety instructions:

- Use only the power cord that comes with the product. Use of another cord may cause fire or shock. Do not use the cord with any other equipment.
- Make sure the power cord meets all relevant local safety standards.
- Use only the type of power source indicated on the label.
- Place the product near a wall outlet where the power cord can be easily unplugged.
- Do not let the power cord become damaged or frayed.
- If you use an extension cord with the product, make sure the total ampere rating of the devices plugged into the extension cord does not exceed the cord's ampere rating. Also, make sure the total ampere rating of all devices plugged into the wall outlet does not exceed the wall outlet's ampere rating.
- Avoid locations that are subject to rapid changes in heat or humidity, shocks or vibrations, or dust.
- Leave enough room around the product for sufficient ventilation. Do not block or cover openings in the case or insert objects through the slots.
- Do not place the product near a radiator or heating vent or in direct sunlight.
- Place the product on a flat, stable surface that extends beyond its base in all directions. It will not operate properly if it is tilted or at an angle.
- Make sure the back of the product is at least 10 cm away from the wall.
- Do not open the scanner unit while copying, printing, or scanning.
- Do not spill liquid on the product.
- Do not use aerosol products that contain flammable gases inside or around the product. Doing so may cause fire.
- Except as specifically explained in your documentation, do not attempt to service the product yourself.
- Unplug the product and refer servicing to qualified service personnel under the following conditions: if the power cord or plug is damaged; if liquid has entered the product; if the product has been dropped or the case damaged; if the product does not operate normally or exhibits a distinct change in performance. Adjust only those controls that are covered by the operating instructions.
- When storing or transporting the product, do not tilt it, stand it on its side, or turn it upside down; otherwise ink may leak from the cartridges.
- Be careful not to trap your fingers when closing the scanner unit.

### ***Ink cartridge safety instructions***

- Keep ink cartridges out of the reach of children and do not drink the ink.
- Be careful when you handle used ink cartridges; there may be ink remaining around the ink supply port. If ink gets on your skin, wash it off with soap and water. If it gets in your eyes, flush them immediately with water. If you still have discomfort or vision problems, see a doctor immediately.
- Do not put your hand inside the product or touch any cartridges during printing.
- Install a new ink cartridge immediately after you remove an expended cartridge. Leaving cartridges uninstalled can dehydrate the print head and may prevent the product from printing.
- If you remove an ink cartridge for later use, protect the ink supply area from dirt and dust and store it in the same environment as the product. Note that there is a valve in the ink supply port, making covers or plugs unnecessary, but care is needed to prevent the ink from staining items that the cartridge touches. Do not touch the ink cartridge, ink supply port, or surrounding area.

## Warnings, Cautions, and Notes

Follow these guidelines as you read your instructions:

### **Warning:**

Warnings must be followed carefully to avoid bodily injury.

### **Caution:**

Cautions must be observed to avoid damage to your equipment.

### **Note:**

Notes contain important information about the product.

### **Tip:**

Tips contain hints for using the product.

## Copyright Notice

No part of this publication may be reproduced, stored in a retrieval system, or transmitted in any form or by any means, electronic, mechanical, photocopying, recording, or otherwise, without the prior written permission of Seiko Epson Corporation. The information contained herein is designed only for use with this product. Epson is not responsible for any use of this information as applied to other printers.

Neither Seiko Epson Corporation nor its affiliates shall be liable to the purchaser of this product or third parties for damages, losses, costs, or expenses incurred by the purchaser or third parties as a result of accident, misuse, or abuse of this product or unauthorized modifications, repairs, or alterations to this product, or (excluding the U.S.) failure to strictly comply with Seiko Epson Corporation's operating and maintenance instructions.

Seiko Epson Corporation shall not be liable for any damages or problems arising from the use of any options or any consumable products other than those designated as Original Epson Products or Epson Approved Products by Seiko Epson Corporation.

Seiko Epson Corporation shall not be held liable for any damage resulting from electromagnetic interference that occurs from the use of any interface cables other than those designated as Epson Approved Products by Seiko Epson Corporation.

EPSON® is a registered trademark and EPSON STYLUS™ and Exceed Your Vision are trademarks of Seiko Epson Corporation.

USB DIRECT-PRINT™ and the USB DIRECT-PRINT logo are trademarks of Seiko Epson Corporation. Copyright © 2002 Seiko Epson Corporation. All rights reserved.

DPOF™ is a trademark of CANON INC., Eastman Kodak Company, Fuji Photo Film Co., Ltd. and Matsushita Electric Industrial Co., Ltd.

SDHC™ is a trademark.

Memory Stick, Memory Stick Duo, Memory Stick PRO, and Memory Stick PRO Duo are trademarks of Sony Corporation.

xD-Picture Card™ is a trademark of Fuji Photo Film Co., Ltd.

**General Notice:** Other product names used herein are for identification purposes only and may be trademarks of their respective owners. Epson disclaims any and all rights in those marks.

Copyright © 2006 Seiko Epson Corporation. All rights reserved.

# Guide to Parts and Control Panel Functions

## Parts

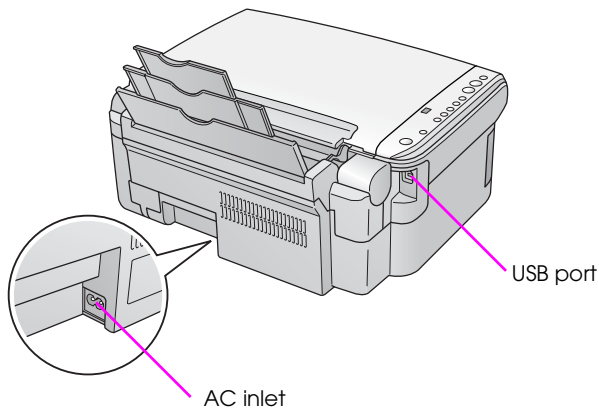
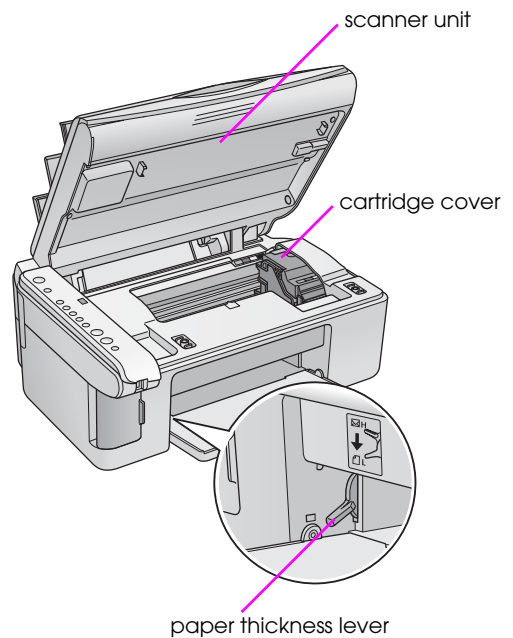
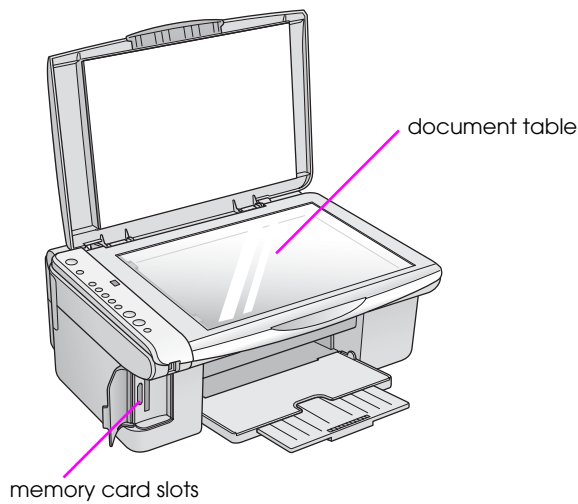
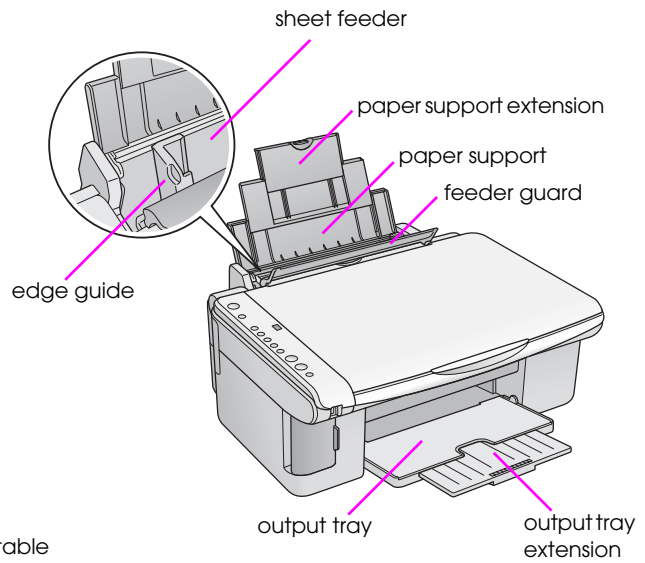
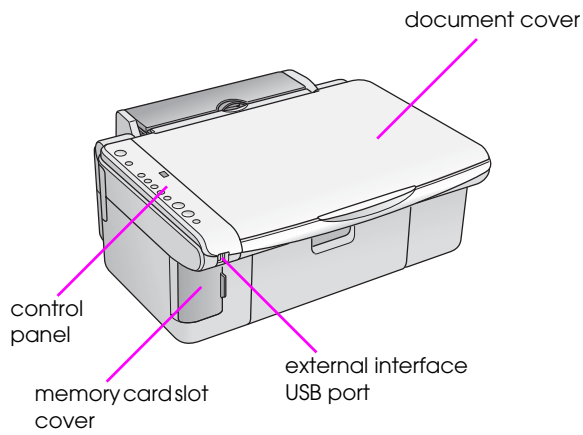

# Control Panel Functions

## Buttons

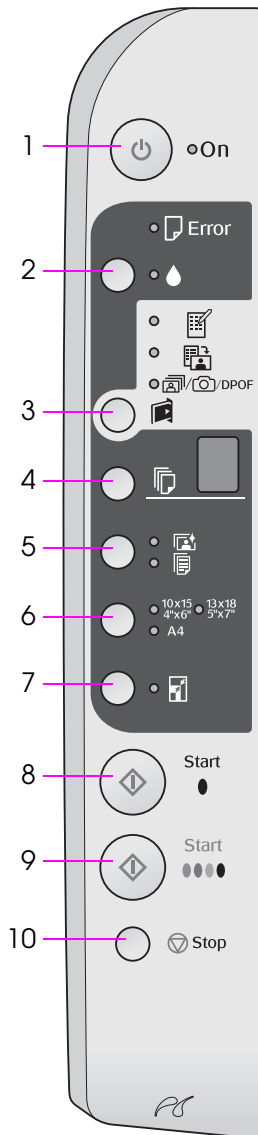

	Button	Function
1	⏻ On	Press to turn the product on and off.
2	💧	Press to replace ink cartridges. Press and hold for three seconds to clean the print head (when the 💧 light is off).
3	📄 [Memory Card]	Press to select a memory card print option.  📄 [Print Index Sheet -A4-] This is normally selected when you press the Memory Card button.  📄 [Print From Index Sheet] This is selected automatically after printing the index sheets for a memory card.  📄/📷/📷 [Print All/DPOF/PictBridge] Select this option to print all the images on a memory card, to print images using the DPOF information stored on the memory card, or to print images directly from a digital camera.  <b>Note:</b> DPOF mode is only available when the images on the memory card contain DPOF information. To print all images on the memory card, turn off DPOF mode on your camera.
4	📄 [Copies]	Press to set the number of copies. The number in the window changes from 1 to 9, then -, and then the cycle repeats.
5	📄/📄 [Paper Type]	Press to select a paper type option. Select 📄 for Photo paper loaded in the sheet feeder. Select 📄 for plain paper loaded in the sheet feeder.
6	10 × 15 4" × 6" 13 × 18 5" × 7" A4 [Paper Size]	Press to select the size of the paper loaded in the sheet feeder.
7	📄 [Fit to Page]	Press to reduce or enlarge the copied image to fit the selected paper size.  When copying photos, you can select whether to copy with or without borders (➡ "Copying Photos" on page 11).
8	◇ Start ● [B&W]	Press to copy in black and white.
9	◇ Start 0000 [Color]	Press to copy in color or to start memory card printing.
10	⊘ Stop	Press to stop copying. The sheet being printed is ejected and the number of copies is reset.

# Lights

● = on ● = flashing

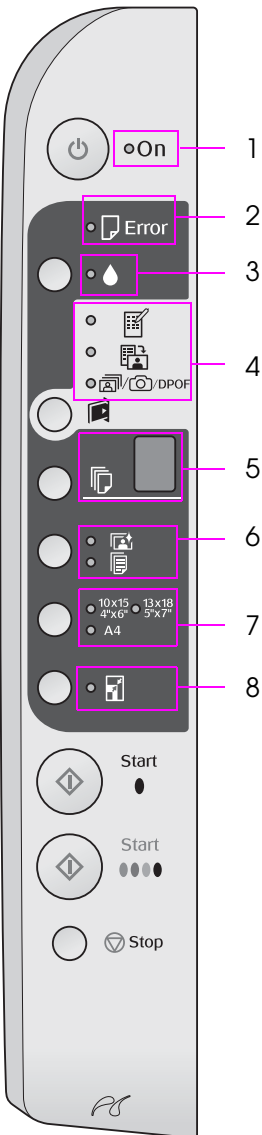

	Light	Pattern	Status
1	On	●	The product is on.
		● (slow)	The product is active.
		● (fast)	The product is turning off.
2	Error	● or ●	An error has occurred (➔ "Solving Problems" on page 22).
3	Ink level indicator	●	An ink cartridge is low. You can continue copying until it is expended.
		●	An ink cartridge is expended or missing.
4	[Print Index Sheet -A4-] [Print From Index Sheet] [Print All/DPOF/PictBridge]	●	One of the memory card printing options has been selected.
		● [Print All/DPOF/PictBridge]	Memory card printing option is in DPOF mode.
5	[Copies] (window)	1 to 9	Indicates the number of copies.
		-	Up to 100 copies will be made, depending on how much paper is loaded.
		E	An error has occurred.
		H	The paper thickness lever has been set to the ☒ (envelope) position.
		L	The paper thickness lever has been set to the ☐ (standard) position.
		P	Flashes when a camera with PictBridge data is connected. When the connected device is not supported, the P double flashes and the Error light and [Print All/DPOF/PictBridge] lights flash.
6	[Photo Paper] [Plain Paper]	●	Indicates the selected paper type.
7	10 × 15 4" × 6" 13 × 18 5" × 7" A4	●	Indicates the selected paper size.
8	[Fit to Page]	●	When selecting [Plain Paper] as the paper type, the copied image is reduced or enlarged to fit the selected paper size with borders.  When selecting [Photo Paper] as the paper type, the copied image is reduced or enlarged to fit the selected paper size without borders.

# Handling Paper

Epson offers an extensive line of special papers that provide outstanding results when used with Epson printers and ink. The type of paper you choose affects the way your printout looks, so be sure to select the correct paper for your job.

## Selecting Paper

If you are just making a copy or printing a rough draft of an image, plain paper is fine. However, for the best results, you will want to use one of Epson's special ink jet papers designed for the product.

Before printing, you need to select the correct Paper Type setting on the control panel. This important setting determines how the ink is applied to the paper.

Choose from these paper types and settings:

Paper type	Size	Paper type setting	Loading capacity
Plain paper*	A4	Plain paper	12 mm
EPSON Bright White Ink Jet Paper	A4	Plain paper	80 sheets
EPSON Premium Ink Jet Plain Paper	A4	Plain paper	100 sheets
EPSON Premium Glossy Photo Paper	10 × 15 (4 × 6 in.) 13 × 18 (5 × 7 in.) A4	Photo paper	20 sheets
EPSON Premium Semigloss Photo Paper	10 × 15 (4 × 6 in.) A4	Photo paper	20 sheets
EPSON Glossy Photo Paper	10 × 15 (4 × 6 in.) 13 × 18 (5 × 7 in.) A4	Photo paper	20 sheets
EPSON Ultra Glossy Photo Paper	10 × 15 (4 × 6 in.) 13 × 18 (5 × 7 in.) A4	Photo paper	20 sheets

\* You can use paper with a weight of 64 to 90 g/m<sup>2</sup>.

## Loading Paper

1. Open and extend the paper support.

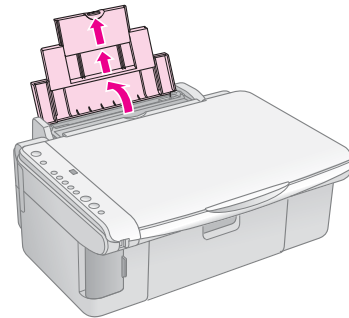

2. Open the output tray and slide out the extensions.

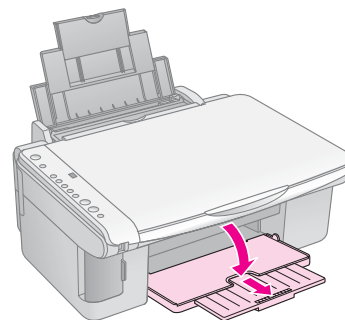

3. Flip the feeder guard forward.

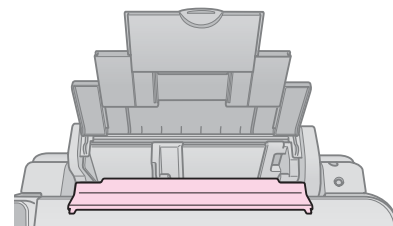
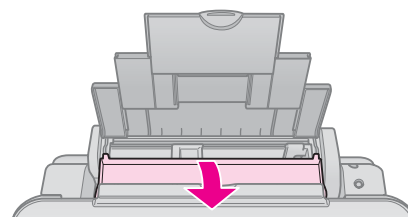



4. Set the paper as shown in the following illustrations.

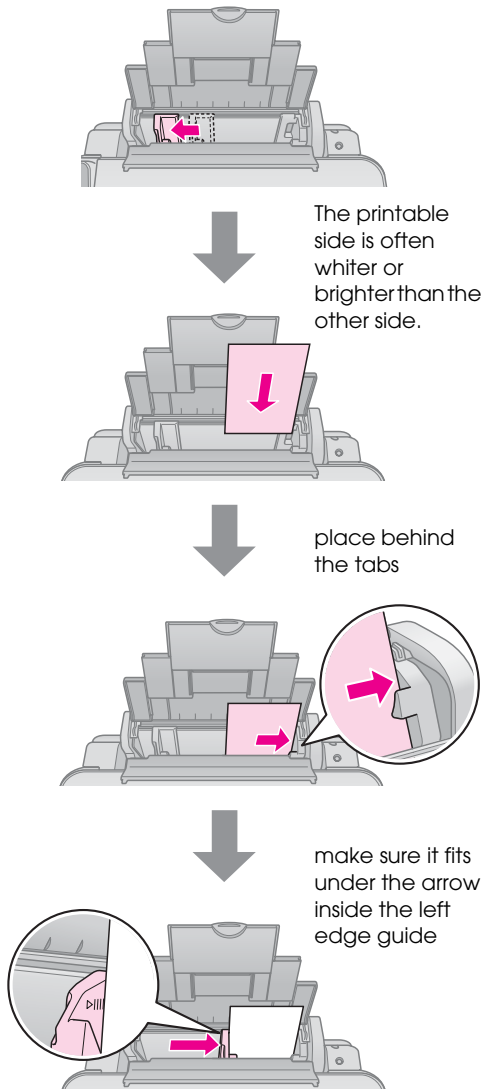

5. Flip the feeder guard back.

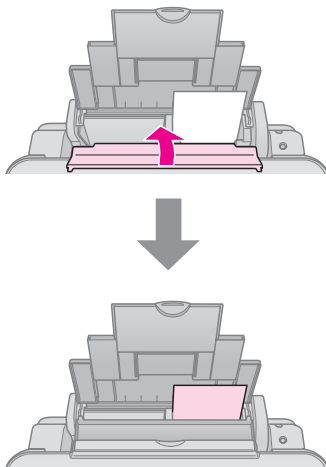

10 × 15 cm (4 × 6 in.)  
and 13 × 18 cm  
(5 × 7 in.)

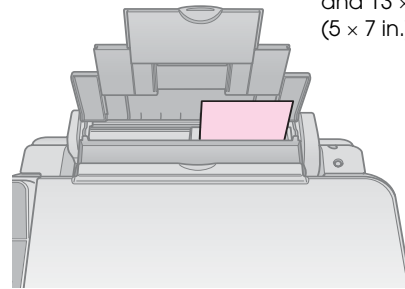

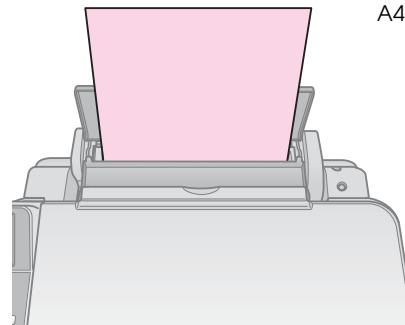

A4

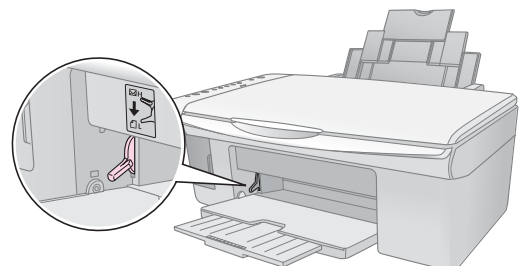

Also make sure the paper thickness lever is set down to the  position.



The letter L appears briefly in the  (Copies) window on the control panel when you move the lever to the  position; the letter H appears when you move it to the  position.

**Note:**

Make sure you do not load more than the recommended number of sheets. Check the **Paper Type** setting before printing to make sure it matches the type of paper you have loaded (➔ “Selecting Paper” on page 8).

# Copying

You can copy documents and photos without a computer.

Note the following when copying:

- The copied image may not be exactly the same size as the original.
- Depending on the type of paper used, print quality may decline in the top and bottom areas of the printout, or these areas may be smeared.
- If you see a low ink indicator while you are copying, you can either continue copying until the ink is expended, or stop and replace the cartridge.
- Keep the document table clean.
- Make sure the document or photo is flat against the document table; otherwise, the copy will be out of focus.
- Do not pull out paper that is being printed; it will be ejected automatically.

## Placing Originals on the Document Table

1. Open the document cover and place your original face-down on the document table, in the upper left corner.

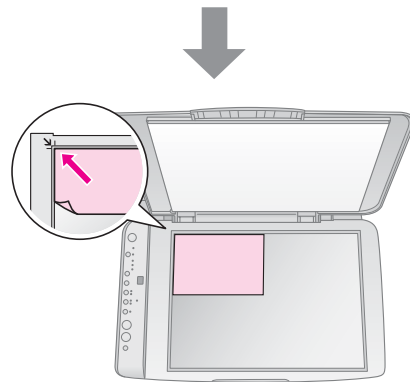
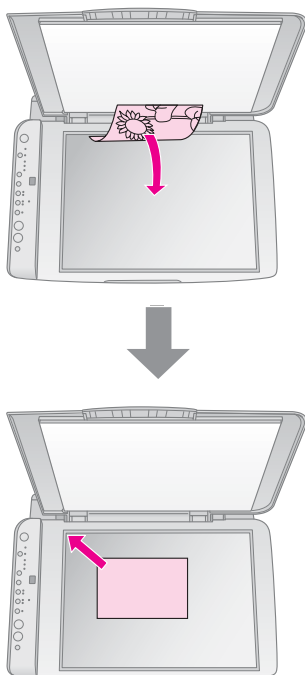

2. Close the cover gently so you do not move the original.

### ⚠ Caution:

Never open the document cover beyond where it stops and do not place heavy objects on top of the product.

If you need to copy a thick or large document, you can remove the document cover. Just open it and pull it straight up.

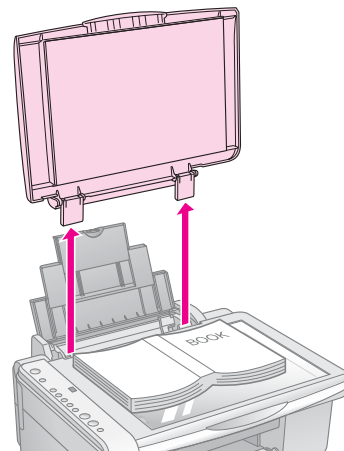

If you need to press the document flat while you copy it, do not press too hard and be careful not to move it.

When you are done, replace the document cover by inserting the tabs back into the slots.

## Copying Documents



### Tip:

Plain photocopier paper works well for making everyday copies. For crisper text and more vivid colors, try one of the special Epson papers (➔ “Selecting Paper” on page 8).

1. Load plain paper (➔ page 8).
2. Place your original on the document table (➔ “Placing Originals on the Document Table” on page 10).
3. Make the following settings on the control panel.

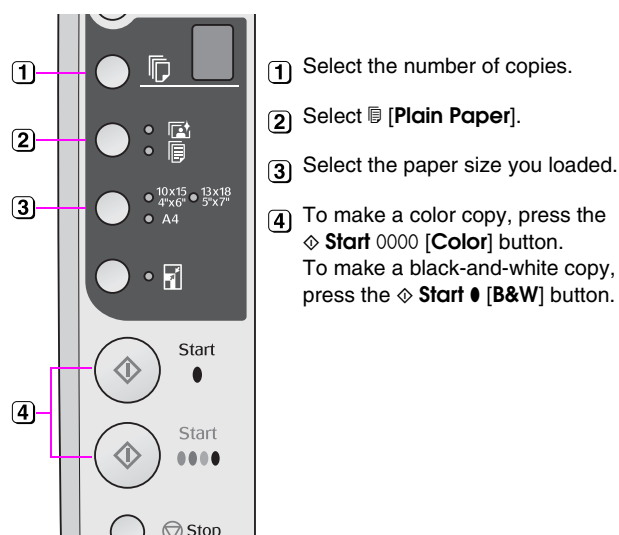

### Tip:

If you want to resize the copy to the size of paper that you loaded automatically, turn on the **[Fit to Page]** light by pressing the **[Fit to Page]** button.

The **On** light flashes, and after a moment your document is copied.

If you need to stop copying, press the **Stop** button.

### Note:

If the edges of the copy are cropped off, move the original away from the corner slightly.

## Copying Photos

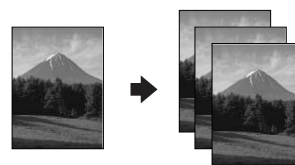

1. Load photo paper (➔ page 8).
2. Place your original on the document table (➔ “Placing Originals on the Document Table” on page 10).
3. Make the following settings on the control panel.

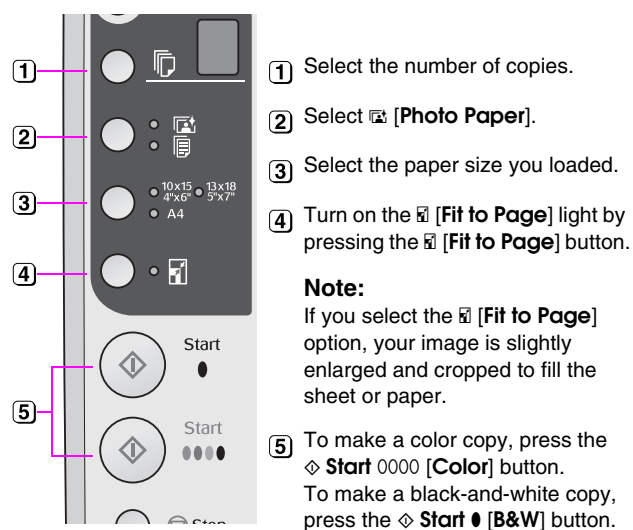

### Tip:

If you want a white border, turn off the **[Fit to Page]** light by pressing the **[Fit to Page]** button.

The **On** light flashes, and after a moment your photo is copied.

If you need to stop copying, press the **Stop** button.

## Speeding Up Copying

If you want to make a copy quickly and do not need high quality, you can print a “draft” copy. The print quality is reduced, but the copy is printed faster.

1. Load A4-size plain paper and select **[Plain Paper]** and **A4** on the control panel.
2. When you are ready to copy, press and hold down the **Stop** button, then press and hold down the **Start 0000 [Color]** button (to copy in color) or the **Start ● [B&W]** button (to copy in black and white).
3. When the **On** light starts flashing, release both buttons.

### Note:

For draft copies, black and color ink are mixed, even for black-and-white copies.

# Printing from a Memory Card

You can print photos directly from your digital camera's memory card. Just insert it into the memory card slot and you are ready to print.

## Handling a Memory Card

### Compatible cards

Make sure your memory card meets the following requirements.

Card type	CompactFlash, Microdrive, SD Memory Card, SDHC Memory Card, MultiMediaCard, miniSD card, miniSDHC card, microSD card, microSDHC card, Memory Stick, Memory Stick PRO, Magic Gate Memory Stick, Magic Gate Memory Stick Duo, Memory Stick Duo, Memory Stick PRO Duo, xD-Picture Card, xD-Picture Card Type M, xD-Picture Card Type H
Media format	DCF (Design rule for Camera File system) version 1.0 or 2.0 compliant All card types standard version compliant.
File format	JPEG with the Exif Version 2.21 standard
Image size	80 × 80 pixels to 9200 × 9200 pixels
Number of files	Up to 999

### Inserting a memory card

1. Turn off your computer or disconnect it from the product.
2. Make sure the product is turned on.
3. Open the memory card slot cover.

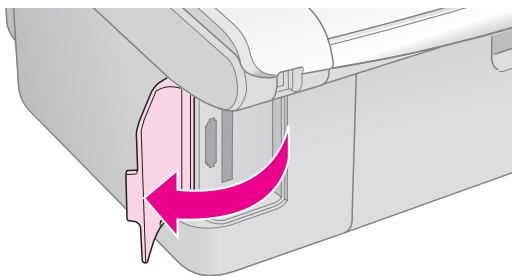

4. Make sure the memory card light is off and no memory cards are in the slots. Then insert your memory card.

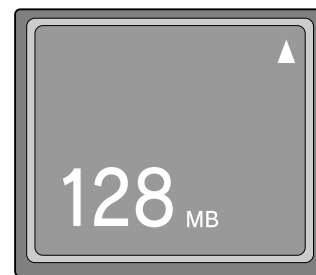
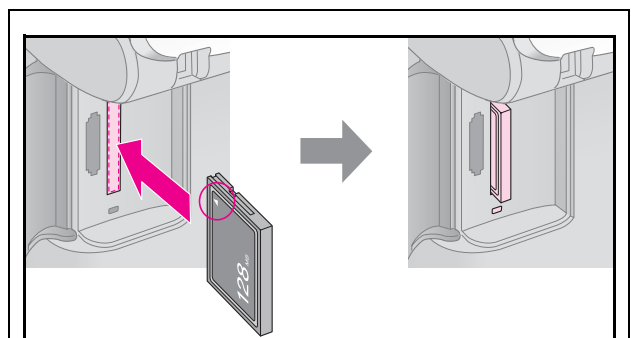
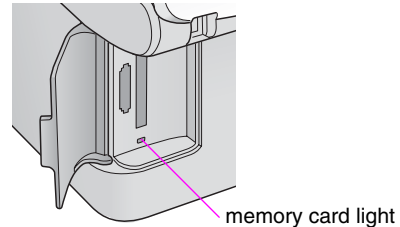

CompactFlash  
Microdrive

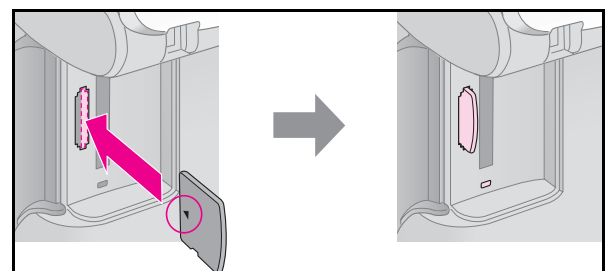

xD-Picture Card  
xD-Picture Card Type M  
xD-Picture Card Type H

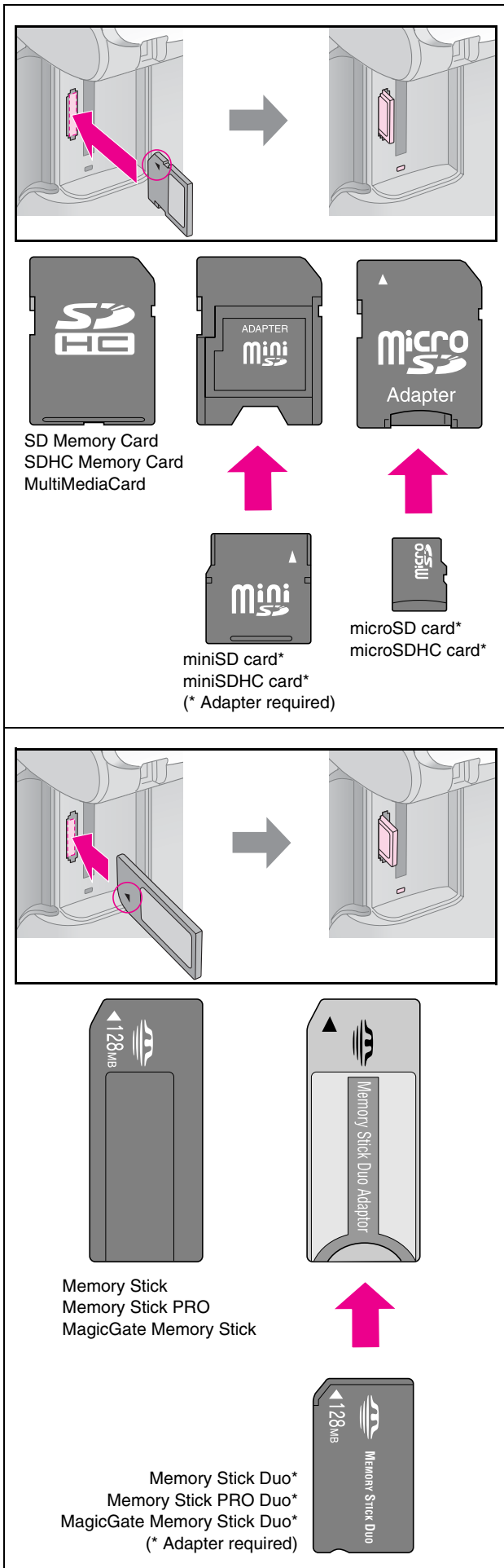

### ⚠ Caution:

Make sure you check which direction the card should be inserted, and if the card needs an adapter make sure you attach the adapter before inserting the card. Otherwise, you may not be able to remove the card from the product.

5. Make sure the memory card light flashes and then stays on.
6. Close the memory card slot cover.

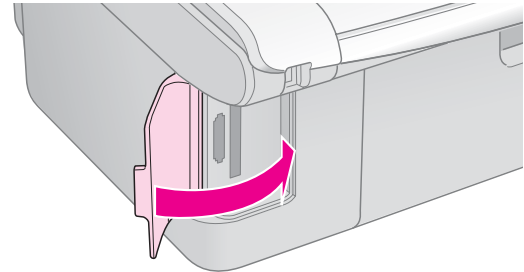

### ⚠ Caution:

- Do not insert more than one memory card at a time.
- Do not try to force the memory card into the slot. Memory cards will not go all the way in. Forcing a memory card into the slot may damage the product, the memory card, or both.
- Keep the memory card slot cover closed while a memory card is inserted. This protects the memory card and the slot from dust and static; otherwise data on the memory card may be lost, or the product may be damaged.
- The static charge on memory cards may cause malfunction.

### Note:

- You can print only in color from a memory card; you cannot print in black and white.
- If a digital camera is connected to the product, disconnect it before you insert your memory card.

## Removing the memory card

1. Make sure all print jobs are finished.
2. Open the memory card slot cover.
3. Make sure the memory card light is not flashing.
4. Remove the memory card by pulling it straight out of its slot.
5. Close the memory card slot cover.

### ⚠ Caution:

- Do not remove the memory card or turn off the product while the memory card light is flashing, or you may lose data on the memory card.
- If your computer uses Windows 2000 or XP, never turn off the product or disconnect the USB cable when a memory card is inserted; you may lose data on the memory card. See your online *User's Guide* for details.

# Selecting and Printing Photos Using an Index Sheet

To select photos for printing, you can use an index sheet. First, print an index sheet which has small images of all the photos on your memory card. Then, mark the photos on the index sheet that you want to print, scan the sheet, and the selected photos will be printed automatically.

## Printing an index sheet

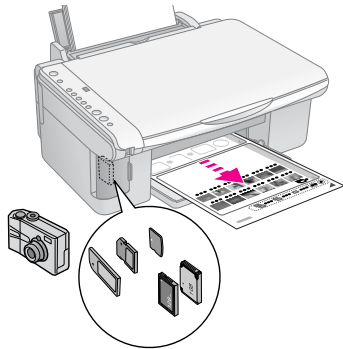

## Selecting photos from the index sheet

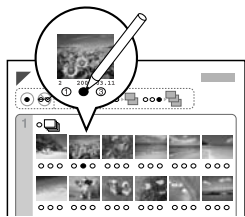

## Scanning the index sheet

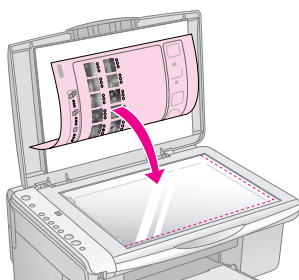

## Printing the selected photos

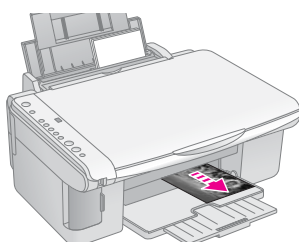

## 1. Printing an index sheet

1. Load several sheets of A4-size plain paper (➔ page 8).

Up to 30 images are printed on each page, so if there are more than 30 photos on your memory card, you will need enough sheets for all the index pages to be printed.

2. Insert a memory card (➔ page 12).
3. Press the [Memory Card] button one or more times until the [Print Index Sheet -A4-] light comes on.

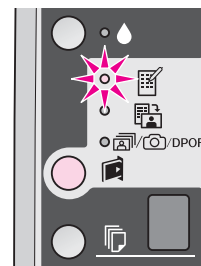

4. Make sure [Plain Paper] and **A4** are selected.
5. Press the **Start 0000 [Color]** button. The **On** light flashes, and the index sheet is printed.

If you need to cancel printing, press the **Stop** button.

### Note:

- Make sure the triangle mark on the upper left corner of the index sheet is printed properly. If the index sheet is not printed correctly, the product cannot scan it.
- If there are a lot of photos on your memory card, this may take a few minutes.
- For multiple index sheets, the pages are printed from the last sheet to the first, so the most recent images are printed first.

## 2. Selecting photos from the index sheet

On the index sheet, use a dark pen or pencil to fill in the circles and make your selections.

Good:



NOT good:



Select **All** to print one copy of each photo, or fill in the number beneath each photo to select 1, 2, or 3 copies.



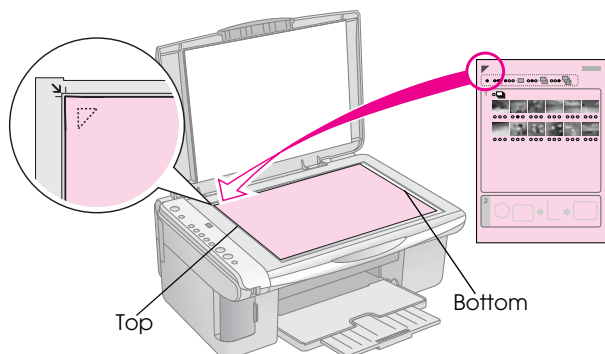

### 3. Scanning the index sheet and printing the selected photos

1. Place the index sheet face-down on the document table, in the upper left corner, so that the top of the sheet is aligned against the left edge of the document table.

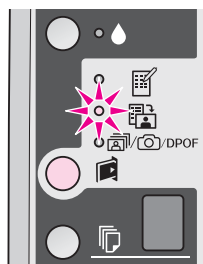

2. Close the document cover.
3. Load the type of paper you want to print on (➔ page 8). Load enough sheets for the number of photos you want to print.
4. Make sure the  [Print From Index Sheet] light is on.



5. Select  [Plain Paper] or  [Photo Paper] (whichever you loaded).  
If you select  [Plain Paper], the photos are printed with a white border. If you select  [Photo Paper], the photos are printed without borders to the edge of the paper.
6. Select the paper size you loaded.
7. Press the  **Start 0000 [Color]** button. The sheet is scanned and your photos are printed.



If you need to stop printing, press the  **Stop** button.

**Note:**

If you have more than one index sheet, wait each time until printing is complete. Then repeat the steps above to scan and print from each additional sheet.

### Printing All Photos or DPOF Photos



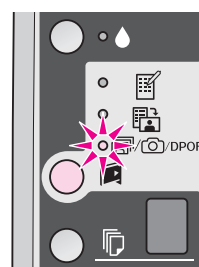

Follow the steps below to print one copy of each photo on the memory card or to print only those photos that were pre-selected with your camera's DPOF feature.

1. Load the type of paper you want to use (➔ page 8). Load enough sheets for the number of photos you want to print.
2. Insert the memory card (➔ page 12).
3. Press the  [Memory Card] button until the  / /DPOF [Print All/DPOF/PictBridge] light comes on.



**Note:**

If the memory card does not contain DPOF information, one copy of all the photos on the memory card will be printed.

4. Select  [Plain Paper] or  [Photo Paper] (whichever you loaded).  
If you select  [Plain Paper], the photos are printed with a white border. If you select  [Photo Paper], the photos are printed without borders to the edge of the paper.
5. Select the paper size you loaded.
6. Press the  **Start 0000 [Color]** button to print your photos.

If you need to cancel printing, press the  **Stop** button.



# Printing from a Digital Camera



You can print your photos by connecting your digital camera directly to this product.



## Digital Camera Requirements

Make sure your camera and photos meet the following requirements.

Direct printing compatibility	PictBridge or USB DIRECT-PRINT
File format	JPEG
Image size	80 × 80 pixels to 9200 × 9200 pixels

## Connecting and Printing

1. Make sure the product is not printing from a computer and remove any memory cards from the product.
2. Load the type of paper you want to use (➔ page 8). Load enough sheets for the number of photos you want to print.
3. Select  [Plain Paper] or  [Photo Paper] (whichever you loaded).

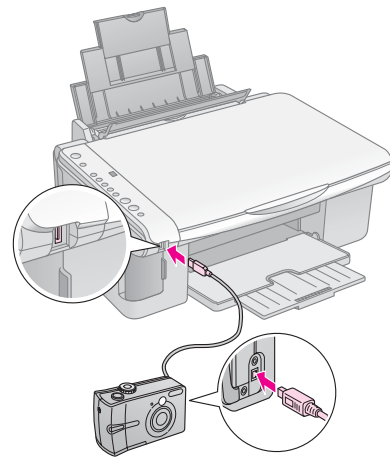

If you select  [Plain Paper], the photos are printed with a white border. If you select  [Photo Paper], the photos are printed without borders to the edge of the paper.

4. Select the paper size you loaded.
5. Connect the USB cable that came with your camera to the external interface USB port of this product.



6. Make sure your camera is turned on and use it to select the photos you want to print, adjust any necessary settings, and print your photos. See your camera's manual for details.

### Note:

- If your camera is not compatible with PictBridge or USB DIRECT-PRINT, a double flashing **P** appears in the  [Copies] window, and the  Error light and the /DPOF [Print All/DPOF/PictBridge] light flash. Epson cannot guarantee the compatibility of any camera.
- Depending on the settings on this product and the digital camera, some combinations of paper type, size, and layout may not be supported.
- Some of the settings on your digital camera may not be reflected in the output.



# Maintenance

You can keep the operation of the product at its best by performing the procedures described in this chapter. Also, this section includes instructions on how to replace ink cartridges and transport the product.

## Replacing Ink Cartridges

When the  ink light starts flashing, one or more cartridges are low on ink. Make sure you have replacement cartridges.

When the  ink light stays on, you need to replace the appropriate cartridges.

### Tip:

If a cartridge is more than six months old, print quality may decline. If necessary, try cleaning the print head (➔ “Cleaning the print head” on page 20). If printouts still do not look their best, you may need to replace the cartridge.

### Checking the ink cartridge status

You can also check the ink cartridge status when checking the print head (➔ “Checking the print head” on page 20). You can see the percentage of ink left in each cartridge on a printed test pattern.

When your ink starts getting low, make sure you have replacement cartridges available. You cannot print if a cartridge is expended.

### Note:

Epson cannot guarantee the quality or reliability of non-genuine ink. If non-genuine ink cartridges are installed, the ink cartridge status will not be displayed.

### Purchasing ink cartridges

Use these Epson ink cartridges within six months of installing them and before the expiration date.

Color	Part Number	
	DX5000 series	CX4900 series
Black	T0711	T0731
Cyan	T0712	T0732
Magenta	T0713	T0733
Yellow	T0714	T0734

### Caution:

Epson recommends the use of genuine Epson ink cartridges. The use of non-genuine ink may cause damage that is not covered by Epson's warranties, and under certain circumstances, may cause erratic printer behavior. Epson cannot guarantee the quality or reliability of non-genuine ink. Information about the ink cartridge status is not displayed when non-genuine ink is used.

## Ink cartridge precautions

### Warning:

If ink gets on your hands, wash them thoroughly with soap and water. If ink gets in your eyes, flush them immediately with water. If you still have discomfort or vision problems, see a doctor immediately.

- To avoid damaging the product, never move the print head by hand.
- When an ink cartridge is expended, you cannot continue copying or printing even if the other cartridges still contain ink.
- Leave the expended cartridge installed until you have obtained a replacement. Otherwise the ink remaining in the print head nozzles may dry out.
- An IC chip on each ink cartridge monitors the amount of ink used from the cartridge. Cartridges are usable even if they are removed and reinserted. However, some ink is consumed each time cartridges are inserted because the printer automatically checks their reliability.
- Ink cartridges with low ink status cannot be used when reinserted.

## Removing and installing ink cartridges

Make sure you have a new ink cartridge before you begin. Once you start replacing a cartridge, you must complete all the steps in one session.



1. Make sure the product is on.
2. Make sure the document cover is closed, then lift up the scanner unit.

### Caution:

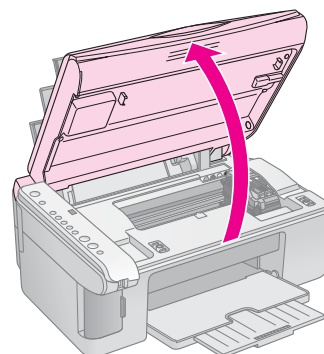
Do not lift up the scanner unit when the document cover is open.



3. Press and release the  ink button.

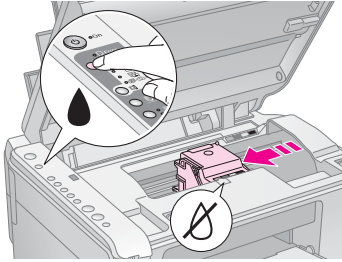

The ink cartridge holder moves to the check position and the **On** and  ink lights flash. If one of the cartridges is low or expended, the product moves that cartridge to the .



If none of the cartridges are low or expended, the print head moves to the ink cartridge replacement position. Go to step 5.

**Note:**

Do not hold down the  ink button. If it is held down for three or more seconds, print head cleaning begins.

4. Press the  ink button again.
  - If more than one cartridge is expended or low, the next cartridge moves to the .
  - When all of the expended or low ink cartridges have been identified, the print head moves to the ink cartridge replacement position.

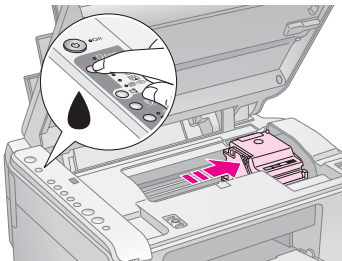

5. Open the cartridge cover.

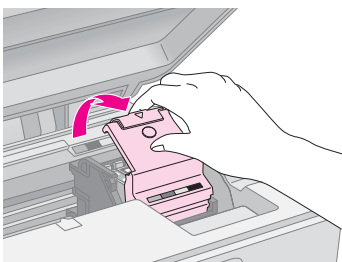

**Caution:**

- ❑ Never attempt to open the cartridge cover while the print head is moving. Wait until the cartridges have moved to the replacement position.
- ❑ Be careful not to touch the parts highlighted below.

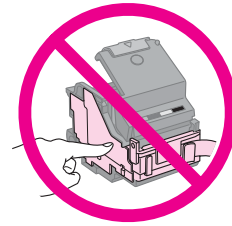

6. Remove the cartridge you need to replace. Squeeze the tab at the back of the cartridge and lift it straight out. Dispose of it carefully.

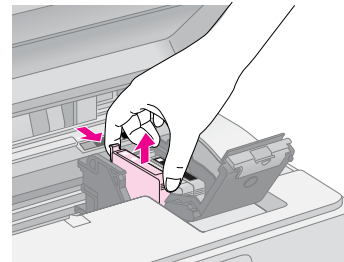

**Caution:**

Do not refill the ink cartridge. Other products not manufactured by Epson may cause damage that is not covered by Epson's warranties, and under certain circumstances, may cause erratic printer behavior.

7. Before you open the new ink cartridge package, shake it four or five times. Then remove it from the package.

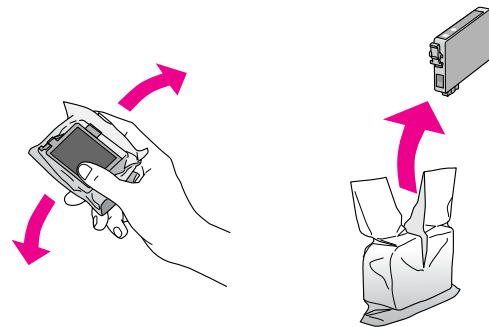

**Caution:**

Do not touch the green chip on the side of the cartridge. This can damage the ink cartridge.

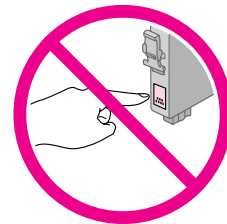

8. Remove the yellow tape from the bottom of the ink cartridge.

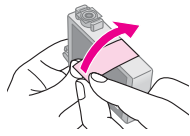

**Caution:**

- ❑ You must remove the yellow tape from the cartridge before installing it; otherwise, print quality may decline or you may not be able to print.
- ❑ If you have installed an ink cartridge without removing the yellow tape, take the cartridge out of the printer, remove the yellow tape, and then reinstall it.
- ❑ Do not remove the transparent seal from the bottom of the cartridge; otherwise, the cartridge may become unusable.

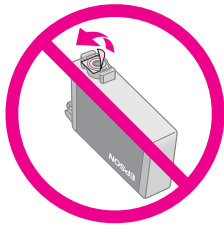

- ❑ Do not remove or tear the label on the cartridge; otherwise, ink will leak.

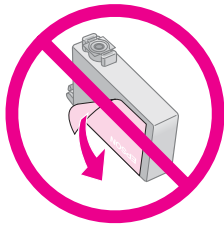

9. Place the new ink cartridge into the holder and push it down until it clicks into place.

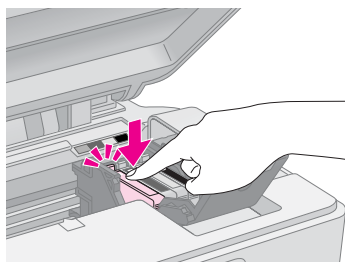

10. Replace any other ink cartridges that need to be replaced.
11. Close the ink cartridge cover and press it until it clicks into place.

**Caution:**

If you find it difficult to close the cover, make sure all the cartridges are firmly seated. Press down on each cartridge until you hear it click into place. Do not attempt to force the cover closed.

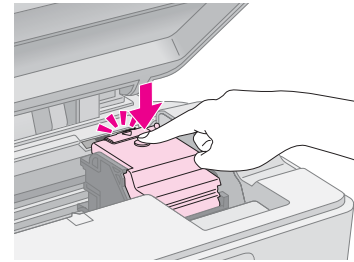

12. Close the scanner unit.

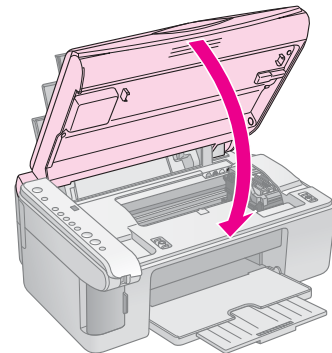

13. Press the **◆** ink button.

The product begins charging ink and the **On** light starts flashing. This takes about one minute. When it has finished, the **On** light stops flashing and remains on, and the **◆** ink light goes out.

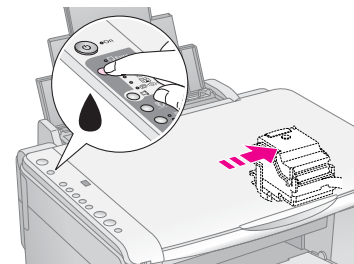

**Caution:**

Do not turn off the product during ink charging as this will waste ink.

**Note:**

If the **◆** ink light stays on (not flashing), the ink cartridge may not be installed correctly. Press the **◆** ink button again and reinstall the ink cartridge until it clicks into place.

# Checking and Cleaning the Print Head



If your printouts are unexpectedly light, colors are missing, or you see light or dark lines across the page, you may need to clean the print head. This clears the print head nozzles, which can become clogged if you do not use the product for a long time.

### Tip:

We recommend that you turn on the product at least once a month to maintain good print quality.

## Checking the print head

You can print a nozzle check pattern to see if any print head nozzles are clogged, or to check the results after cleaning the print head.

1. Turn off the product.
2. Load A4-size plain paper (➔ page 8).
3. While holding down the  ink button, press and hold down the  **On** button for about three seconds.

The product turns on and prints a test pattern. It also shows the percentage of ink left in each cartridge:

4. Examine the nozzle check pattern you printed. Each staggered line should be solid, with no gaps, as shown.



- If your printout looks okay, the print head does not need to be cleaned yet.
- If you see any gaps, as shown below, clean the print head as described in the next section.





## Cleaning the print head

Follow these steps to clean the print head so it can deliver ink properly. Before cleaning the print head, run a nozzle check to see if the print head needs cleaning (➔ “Checking the print head” on page 20).

### Note:

- Print head cleaning uses ink, so clean it only if quality declines.
- If the  ink light comes on or flashes, you cannot clean the print head. You must first replace the appropriate ink cartridge (➔ “Replacing Ink Cartridges” on page 17).

1. Make sure the product is on and the  ink light is off.
2. Hold down the  ink button for three seconds until the **On** light starts flashing. A head cleaning cycle begins and the **On** light stays flashing.

### Caution:

Never turn off the product while head cleaning is in progress. You may damage it.

3. When the **On** light stops flashing, print a nozzle check pattern to check the results (➔ “Checking the print head” on page 20).

If there are still gaps or the test patterns are faint, run another cleaning cycle and check the nozzles again.

### Note:







If you do not see any improvement after cleaning three or four times, turn off the product and wait overnight. This lets any dried ink soften. Then try cleaning the print head again. If quality still does not improve, one of the ink cartridges may be old or damaged and needs to be replaced (➔ “Replacing Ink Cartridges” on page 17).

## Aligning the Print Head

If you notice that vertical lines are not aligned properly on the nozzle check printout, you may be able to solve this problem by aligning the print head.

You can align the print head by pressing the buttons, or you can run the Print Head Alignment utility from your computer. For the most accurate alignment, the utility is recommended.

Follow these steps to align the print head using the buttons:

1. Make sure the product is turned off.
2. Load A4-size plain paper (➔ page 8).
3. While holding down the  [**Copies**] button, press and hold down the  **On** button for about three seconds.  
  
Four rows of alignment patterns are printed.
4. Look at pattern #1 and find the patch that is most evenly printed, with no noticeable streaks or lines.
5. Press the  [**Copies**] button until the number for that patch appears in the  [**Copies**] window.
6. Press the  **Start**  [**B&W**] button.
7. Repeat steps 5 and 6 for each of the other alignment patterns.

## Cleaning This Product

To keep the operation of the product at its best, clean it periodically using the following procedure.

1. Unplug the power cord.
2. Remove all paper from the sheet feeder.
3. Use a soft brush to carefully clean away all dust and dirt from the sheet feeder.
4. If the glass surface of the document table gets dirty, clean it with a soft, dry, clean cloth. If the glass surface is stained with grease or some other hard-to-remove material, use a small amount of glass cleaner and a soft cloth to remove it. Wipe off all remaining liquid.
5. If the inside of the product accidentally gets soiled with ink, use a soft, dry, clean cloth to wipe the ink off the area indicated in the illustration.

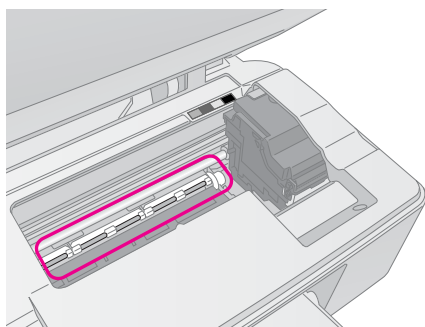

### Warning:

Be careful not to touch the gears or rollers inside the product.

### Caution:

- ❑ Do not press the glass surface of the document table with any force.
- ❑ Be careful not to scratch or damage the glass surface of the document table, and do not use a hard or abrasive brush to clean it. A damaged glass surface can decrease the scan quality.
- ❑ Do not apply grease to the metal parts under the print head carriage.
- ❑ Never use alcohol or thinner to clean the product. These chemicals can damage the components as well as the case.
- ❑ Be careful to keep water away from the printing and scanning mechanisms and electronic components.
- ❑ Do not spray the inside of the product with lubricants. Unsuitable oils can damage the mechanism. Contact your dealer or a qualified service person if lubrication is needed.

## Transporting This Product

If you need to move the product some distance, you need to prepare it for transportation in its original box or one of a similar size.

### Caution:

- ❑ When storing or transporting the product, avoid tilting it, placing it vertically, or turning it upside down; otherwise ink may leak from the cartridges.
- ❑ Leave the ink cartridges installed; removing the cartridges for transportation may damage the product.

1. Remove all paper from the sheet feeder and make sure the product is off.
2. Open the scanner unit and make sure the print head is in the home position on the right.
3. Secure the ink cartridge holder to the case with tape as shown.

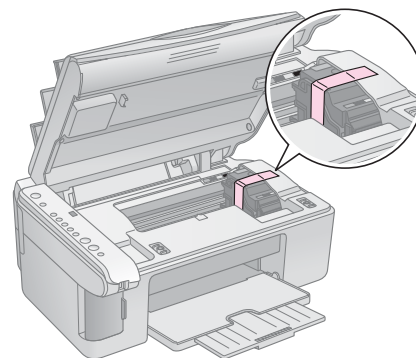

4. Close the scanner unit.
5. Unplug the power cord from the outlet, then disconnect the USB cable from your computer.
6. Close the paper support, the feeder guard, and the output tray.

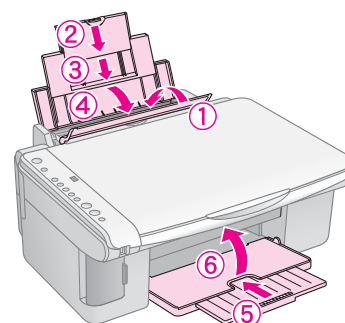

7. Repack the product in the box, using the protective materials that came with it.

Keep the product level as you transport it. After you move it, remove the tape securing the print head. If you notice a decline in print quality, run a cleaning cycle (➔ “Checking and Cleaning the Print Head” on page 20) or align the print head (➔ “Aligning the Print Head” on page 20).

# Solving Problems

If you have a problem with the product, check the lights on the control panel and the code number or letter in the  [Copies] window to diagnose what may be causing the problem.



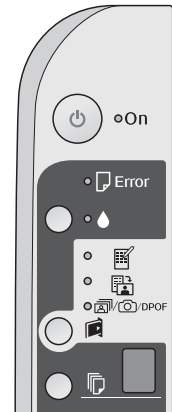





















You can also check “Problems and Solutions” on page 24 for troubleshooting suggestions on using the product without a computer. See the *User’s Guide* included in the software CD-ROM for help on using the product with a computer.



## Error Indicators

●: Indicates light on

●: Indicates light is flashing

Lights/Code	Cause	Solution
●  Error	No paper is loaded in the sheet feeder.	Load paper in the sheet feeder (➔ “Handling Paper” on page 8). Then press  <b>Start</b> 0000 [Color] to continue or  <b>Stop</b> to cancel.
	Multiple pages have been fed into the sheet feeder.	Remove and reload the paper (➔ “Handling Paper” on page 8). Then press  <b>Start</b> 0000 [Color] to continue or  <b>Stop</b> to cancel.
●  Error	Paper is jammed.	Clear the jammed paper (➔ “Paper feed problems” on page 24).
● 	An ink cartridge is running low on ink.	Replace the ink cartridge (➔ “Replacing Ink Cartridges” on page 17).
● 	An ink cartridge is expended or not installed correctly.	If any cartridge is expended, you cannot print until you replace it. Replace the ink cartridge (➔ “Replacing Ink Cartridges” on page 17).
●  Error ●  Print Index Sheet -A4- ●  Print From Index Sheet ●  /DPOF Print All/DPOF/PictBridge  [Copies] 	An unsupported memory card is inserted.	Remove the memory card (➔ “Handling a Memory Card” on page 12).
	The memory card does not contain any valid images.	
●  Error ●  Print From Index Sheet  [Copies] 	An index sheet was not recognized because it is not positioned correctly.	Position the index sheet correctly on the document table, aligning the top of it with the left edge of the glass. Then press  <b>Start</b> 0000 [Color] to continue or  <b>Stop</b> to cancel.  The index sheet was not printed correctly. Print the index sheet, mark it, and try again (➔ “Selecting and Printing Photos Using an Index Sheet” on page 14).
●  Error ●  Print From Index Sheet  [Copies] 	The index sheet is marked incorrectly.	Remove the index sheet, mark it correctly, and try again (➔ “2. Selecting photos from the index sheet” on page 14).

Lights/Code	Cause	Solution
<ul style="list-style-type: none"> <li>●  Error</li> <li>●  <b>Print From Index Sheet</b></li> <li> [Copies] <span style="border: 1px solid black; padding: 2px;">4</span></li> </ul>	The index sheet does not match the photos on the memory card.	Remove the memory card and insert the card used to print the index sheet—or place the correct index sheet on the document table. Then press <b>Start</b> 0000 [ <b>Color</b> ] to continue or <b>Stop</b> to cancel.
<ul style="list-style-type: none"> <li>●  Error</li> <li>● /DPOF <b>Print All/DPOF/PictBridge</b></li> <li> [Copies] <span style="border: 1px solid black; padding: 2px;">P</span></li> <li>Code P double flashing</li> </ul>	An unsupported device is connected.	Remove the connected device or press the <b>Stop</b> button.  When a digital camera is supported, the <b>P</b> flashes normally.
<ul style="list-style-type: none"> <li>●  Error</li> <li> [Copies] <span style="border: 1px solid black; padding: 2px;">H</span></li> </ul>	The paper thickness lever is set to the  position.	Set the lever to the  position.
<ul style="list-style-type: none"> <li>●  Error</li> <li>● </li> <li>● All other lights</li> <li> [Copies] <span style="border: 1px solid black; padding: 2px;">E</span></li> </ul>	Waste ink pad in the printer is saturated.	Contact your dealer to replace it (➔ “Contacting Customer Support” on page 26).
<ul style="list-style-type: none"> <li>● All lights</li> <li> [Copies] <span style="border: 1px solid black; padding: 2px;">E</span></li> </ul>	There is a problem with the product.	Turn the product off and then back on. If the error does not clear, contact your dealer (➔ “Contacting Customer Support” on page 26).

# Problems and Solutions

Check the solutions below if you are having problems using the product.

## Setup problems

**The product makes noise after you turn it on.**

- Make sure the protective tape is not blocking the print head. After releasing the print head, turn off the power, wait a moment, then turn it back on.

**The product makes noise after ink cartridge installation.**

- When you install ink cartridges, the ink delivery system must be charged. Wait until charging is finished, then turn off the product. If you turn it off too soon, it may use extra ink the next time you turn it on.
- Make sure the ink cartridges are seated securely and no protective material remains in the product. Open the cartridge cover and push the cartridges down until they click into place. Turn off the power, wait a moment, then turn it back on.

**A screen that prompts you to restart the computer did not appear after finishing the software installation.**

- The software has not been installed correctly. Eject and insert the CD-ROM, and then install the software again.

## Printing and copying problems

**The product is on, but nothing prints.**

- Run a nozzle check (➔ “Checking the print head” on page 20). If nothing prints, you may need to clean the print head.

**The product makes printing sounds, but nothing prints.**

- The print head nozzles may need cleaning (➔ “Checking the print head” on page 20).
- Make sure the product is on a flat, stable surface.

**The margins are incorrect.**

- Make sure your original is positioned in the top left corner of the document table.
- If the edges of the copy are cropped off, move the original away from the corner slightly.
- Make sure the paper size settings are correct for the paper you have loaded.



- Make sure your paper is loaded short edge first, all the way to the right, with the left edge guide lightly against the paper (➔ “Loading Paper” on page 8).
- Do not load paper above the ≡ arrow mark inside the left edge guide (➔ “Loading Paper” on page 8).

**Blank pages are printed.**

- Make sure the paper size settings are correct for the paper you have loaded.
- The print head nozzles may need cleaning (➔ “Cleaning the print head” on page 20).

## Paper feed problems

**Paper does not feed correctly or is jammed.**

- If paper does not feed, remove it from the sheet feeder. Fan the paper, load it against the right side, and slide the left edge guide against the paper (but not too tightly). Make sure the paper is not in front of the feeder guard.
- Do not load paper above the ≡ arrow mark inside the left edge guide (➔ “Loading Paper” on page 8).
- If paper is jammed, the  **Error** light flashes. Follow these steps to clear the jam:
  1. Press the  **Start** 0000 [**Color**] button to eject the jammed paper. If the jammed paper is not ejected, go on to the next step.
  2. If the paper is stuck near the sheet feeder or output tray, gently pull it out then press the  **Start** 0000 [**Color**] button.

If the paper is stuck inside the product, press the  **On** button to turn it off. Open the scanner unit and remove any paper inside, including any torn pieces. Do not pull it backward; this can damage the sheet feeder. Close the scanner unit, then turn the product back on.

- If paper jams frequently, make sure the left edge guide is not pushed too tightly against the paper. Try loading fewer sheets of paper.



## Print quality problems

You see banding (light lines) in your printouts or copies.



- Clean the print head (➔ “Checking the print head” on page 20).
- Make sure you select the correct paper type (➔ “Selecting Paper” on page 8).
- Make sure the printable (whiter or glossier) side of the paper is face-up.
- The ink cartridges may need replacing (➔ “Removing and installing ink cartridges” on page 17).
- Align the print head (➔ “Aligning the Print Head” on page 20).
- Clean the document table (➔ “Cleaning This Product” on page 21).

Your printout is blurry or smeared.



- Make sure the document is placed flat against the document table. If only part of the image is blurred, your original may be wrinkled or warped.
- Make sure the product is not tilted or placed on an uneven surface.
- Make sure your paper is not damp, curled, or loaded face-down (the whiter or glossier printable side should be face-up). Load new paper face-up.
- Use a support sheet with special paper or try loading your paper one sheet at a time.
- Load your paper one sheet at a time. Remove sheets from the output tray so not too many collect at a time.
- Align the print head (➔ “Aligning the Print Head” on page 20).
- Make several copies without placing a document on the document table.

- Use only paper recommended by Epson and genuine Epson cartridges.
- Set the paper thickness lever to the  position for most paper types. If you are printing on envelopes, set the lever to the  position.
- Clean the document table (➔ “Cleaning This Product” on page 21).

Your printout is faint or has gaps.

- Clean the print head (➔ “Cleaning the print head” on page 20).
- If you notice jagged vertical lines, you may need to align the print head (➔ “Aligning the Print Head” on page 20).
- The ink cartridges may be old or low on ink. Replace the ink cartridges (➔ “Replacing Ink Cartridges” on page 17).
- Make sure you select the correct paper type (➔ “Selecting Paper” on page 8).
- Make sure your paper is not damaged, old, dirty, or loaded face-down. If it is, load new paper with the whiter or glossier side face-up.

Your printout is grainy.

- If you are printing or copying a photo, make sure you are not enlarging it too much. Try printing it smaller.
- Align the print head (➔ “Aligning the Print Head” on page 20).

You see incorrect or missing colors.

- Clean the print head (➔ “Cleaning the print head” on page 20).
- The ink cartridges may be old or low on ink. Replace the ink cartridges (➔ “Replacing Ink Cartridges” on page 17).
- Make sure you loaded the right paper and selected the correct setting for it on the control panel.
- If your paper runs out, replace it as soon as possible. If the product is left without paper for a long period of time, the colors of your next copy or print job may be incorrect.

The image size or position is incorrect.

- Make sure you loaded the right paper and selected the correct setting for it on the control panel.
- Make sure the original is placed correctly on the document table (➔ “Placing Originals on the Document Table” on page 10).

- Clean the document table (➔ “Cleaning This Product” on page 21).

## Other problems

When you turn off the product, a red lamp inside the product may remain on.

- The lamp will stay on for a maximum of 15 minutes, then go out automatically. This does not indicate malfunction.

## Contacting Customer Support

### Regional customer services

If your Epson product is not operating properly and you cannot solve the problem using the troubleshooting information in your product documentation, contact customer support services for assistance. If customer support for your area is not listed below, contact the dealer where you purchased your product.

Customer support will be able to help you much more quickly if you give them the following information:

- Product serial number  
(The serial number label is usually on the back of the product.)
- Product model
- Product software version  
(Click **About, Version Info**, or a similar button in the product software.)
- Brand and model of your computer
- Your computer operating system name and version
- Names and versions of the software applications you normally use with your product

#### Note:

For more information on contacting customer support, see the online *User's Guide*.

Europe	
URL	<a href="http://www.epson.com">http://www.epson.com</a> Select the Support section of your local EPSON web site for the latest drivers, FAQs, manuals and other downloadables.
Check your Pan-European Warranty Document for information on how to contact EPSON Customer support.	

# EPSON

EXCEED YOUR VISION



MEMORY STICK PRO™



## Purchasing ink cartridges

Product name	Black	Cyan	Yellow	Magenta
DX5000 series	T0711	T0712	T0714	T0713
CX4900 series	T0731	T0732	T0734	T0733