

SC-F2100 Series

Operator's Guide

Copyrights and Trademarks

Copyrights and Trademarks

No part of this publication may be reproduced, stored in a retrieval system, or transmitted in any form or by any means, electronic, mechanical, photocopying, recording, or otherwise, without the prior written permission of Seiko Epson Corporation. The information contained herein is designed only for use with this Epson printer. Epson is not responsible for any use of this information as applied to other printers.

Neither Seiko Epson Corporation nor its affiliates shall be liable to the purchaser of this product or third parties for damages, losses, costs, or expenses incurred by the purchaser or third parties as a result of accident, misuse, or abuse of this product or unauthorized modifications, repairs, or alterations to this product, or (excluding the U.S.) failure to strictly comply with Seiko Epson Corporation's operating and maintenance instructions.

Seiko Epson Corporation shall not be liable for any damages or problems arising from the use of any options or any consumable products other than those designated as Original Epson Products or Epson Approved Products by Seiko Epson Corporation.

Seiko Epson Corporation shall not be held liable for any damage resulting from electromagnetic interference that occurs from the use of any interface cables other than those designated as Epson Approved Products by Seiko Epson Corporation.

EPSON, EPSON EXCEED YOUR VISION, EXCEED YOUR VISION and their logos are registered trademarks or trademarks of Seiko Epson.

Microsoft® and Windows® are registered trademarks of Microsoft Corporation.

Apple, Mac, macOS, Bonjour are registered trademarks of Apple, Inc.

Adobe, Acrobat, Illustrator, Photoshop, and Reader are either registered trademarks or trademarks of Adobe Systems Incorporated in the United States and/or other countries.

General Notice: Other product names used herein are for identification purposes only and may be trademarks of their respective owners. Epson disclaims any and all rights in those marks.

© 2017 Seiko Epson Corporation. All rights reserved.

Contents

Copyrights and Trademarks

Introduction

Viewing the Manuals. 4

 Meaning of Symbols. 4

 Screenshots. 4

 Illustrations. 4

 Manual Organization. 4

 Opening and Viewing Manuals. 4

Part Names. 7

 Front section. 7

 Interior. 8

 Rear section. 8

Basic Printing

Preparation. 9

 Device for Fixating Ink. 9

 Under Normal Usage. 9

 Items for Use in Pre-treatment (Only when Using White Ink). 9

Overview. 11

Before Printing. 13

Creating and Sending Jobs. 13

 Workflow for Creating and Sending Jobs. 13

 Notes on Receiving Jobs. 14

Preparing the Platen. 14

 Attaching/Removing a Grip Pad. 15

 Replacing Platens and Removing/Attaching Spacers. 17

Load the T-shirt (media). 20

 Adjusting the Platen Gap. 22

Starting and Canceling Printing. 25

 Starting. 25

 Canceling. 25

Fixating the Ink. 26

 Precautions when Fixating the Ink. 26

 Fixating conditions. 26

Maintenance

When to Perform Various Maintenance Operations. 27

 Cleaning Locations and Cleaning Timing. 27

 Locations of Consumables and Replacement Timing. 28

 Other maintenance. 29

Preparation. 30

Cautions when operating. 31

Using ink cleaner. 32

Disposal of used consumables. 33

 Disposal. 33

Cleaning the Suction Cap. 33

Cleaning the scale and replacing the filter. 36

Checking for clogged nozzles. 38

 Loading media. 38

 Printing a Nozzle Check Pattern 39

Cleaning the print head. 40

 Notes on head cleaning. 40

 Cleaning the print head. 40

Shaking and Replacing Ink Cartridges. 42

 Shaking. 42

 Replacement procedure. 42

Disposing of Waste Ink. 44

 Preparing and Replacement Timing. 44

Replacing the Head Cleaning Set. 46

 Preparing and Replacement Timing. 46

 How to Replace the Head Cleaning Set. 47





Options and Consumable Products

. 50

Introduction

Viewing the Manuals

Meaning of Symbols

 Warning:	Warnings must be followed to avoid serious bodily injury.
 Caution:	Cautions must be followed to avoid bodily injury.
 Important:	Important must be followed to avoid damage to this product.
Note:	Notes contain useful or additional information on the operation of this product.
	Indicates related content.

Screenshots

- ❑ Screenshots used in this manual may differ slightly from the actual screen. Screens may also differ depending on the operating system and usage environment.
- ❑ Unless otherwise stated, the Windows screenshots used in this manual are from Windows 10.

Illustrations

The illustrations may differ slightly from the model you are using. Please be aware of this when using the manual.

Manual Organization

The manuals for the product are organized as shown below.

You can view the PDF manuals using Adobe Reader or Preview (macOS).

Setup Guide (booklet)	This manual provides information on how to setup the printer after unpacking it from the box. Make sure you read this manual to perform operations safely.
Operator's Guide (this guide)	This manual explains the necessary basic operations and maintenance for daily use.
General Information (PDF)	This manual provides specifications and contact details for the product.
Online Manual	
User's Guide (PDF)	This manual explains basic operations and necessary items for daily use, maintenance operations, and troubleshooting.
Epson Video Manuals	These videos show you how to load T-shirts (media) and perform maintenance.
Network Guide (PDF)	This manual provides information on using the printer over a network.

Opening and Viewing Manuals

Opening the Online Manual

The Online Manual is available in an environment with an Internet connection.

- 1 See the *Setup Guide* and execute software installation from the supplied software disc or from Setup Navi (<http://epson.sn/>).

When installation is complete, an **EPSON Manuals** icon is created on the desktop of the computer being used.

- 2 Double-click the **EPSON Manuals** icon on your desktop.

Introduction

- 3 Select Online Manual from the screen displayed.
The Web browser launches, and the **Online Manual** top page is displayed.
Click on the manual or item you want to view.

Viewing video manuals

The video manuals have been uploaded to YouTube.

Click **Epson Video Manuals** from the top page of Online Manuals, or click the following blue text to view the manuals.

[Epson Video Manuals](#)

If the subtitles are not displayed when you play the video, click the subtitles icon shown in the image below.

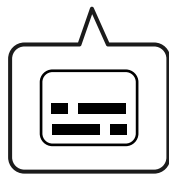

Viewing PDF Manuals

This section uses the Adobe Acrobat Reader as an example to explain the basic operations for viewing the PDF in Adobe Acrobat Reader DC.

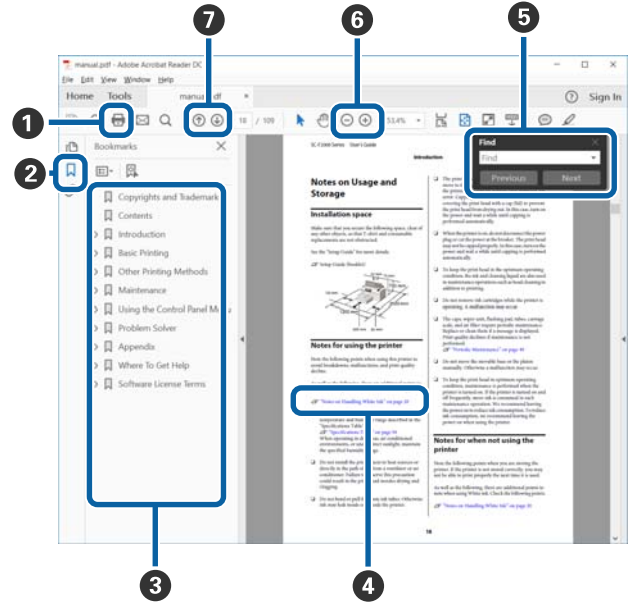

- 1 Click to print the PDF manual.
- 2 Each time it is clicked the bookmarks are hidden or shown.
- 3 Click the title to open the relevant page.
Click [+] to open the titles lower in the hierarchy.
- 4 If the reference is in blue text, click the blue text to open the relevant page.

To return to the original page, do the following.

For Windows

While pressing the Alt key press the ← key.

For macOS

While pressing the command key press the ← key.

Introduction

- 5 You can input and search for keywords, such as the names of items you want to confirm.

For Windows

Right click on a page in the PDF manual and select **Find** in the menu that is displayed to open the search toolbar.

For macOS

Select **Find** in the **Edit** menu to open the search toolbar.

- 6 To enlarge the text in the display that is too small to see well, click **+**. Click **-** to reduce the size. To specify a part of an illustration or screenshot to enlarge, do the following.

For Windows

Right click on the page in the PDF manual and select **Marquee Zoom** in the menu that is displayed. The pointer changes to a magnifying glass, use it to specify the range of the place you want to enlarge.

For macOS

Click **View** menu - **Zoom** - **Marquee Zoom** in this order to change the pointer to a magnifying glass. Use the pointer as a magnifying glass to specify the range of the place you want to enlarge.

- 7 Opens the previous page or next page.

Part Names

Front section

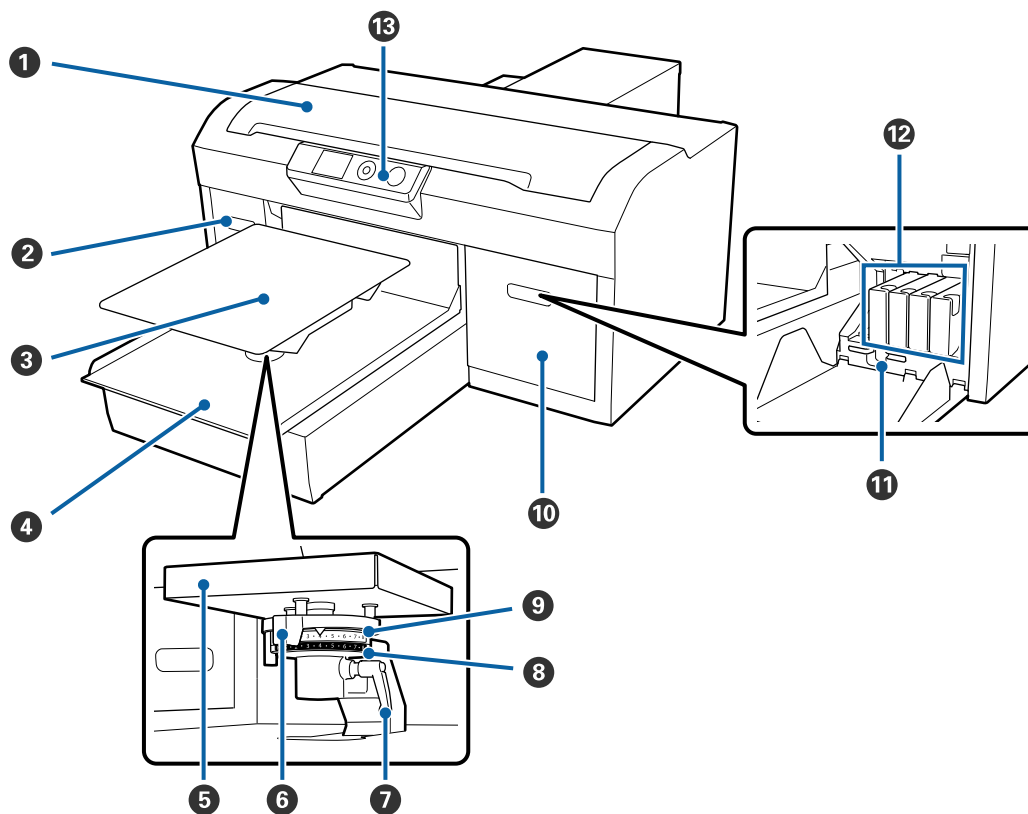

- | | | |
|-----------------------------|-------------------------------|------------------|
| ① Printer cover | ⑥ Platen gap adjustment lever | ⑪ Tweezer holder |
| ② Cartridge cover (left) | ⑦ Fixing lever | ⑫ Ink cartridges |
| ③ Platen | ⑧ Spacer b | ⑬ Control panel |
| ④ Movable base | ⑨ Spacer a | |
| ⑤ Platen installation plate | ⑩ Cartridge cover (right) | |

Introduction

Interior

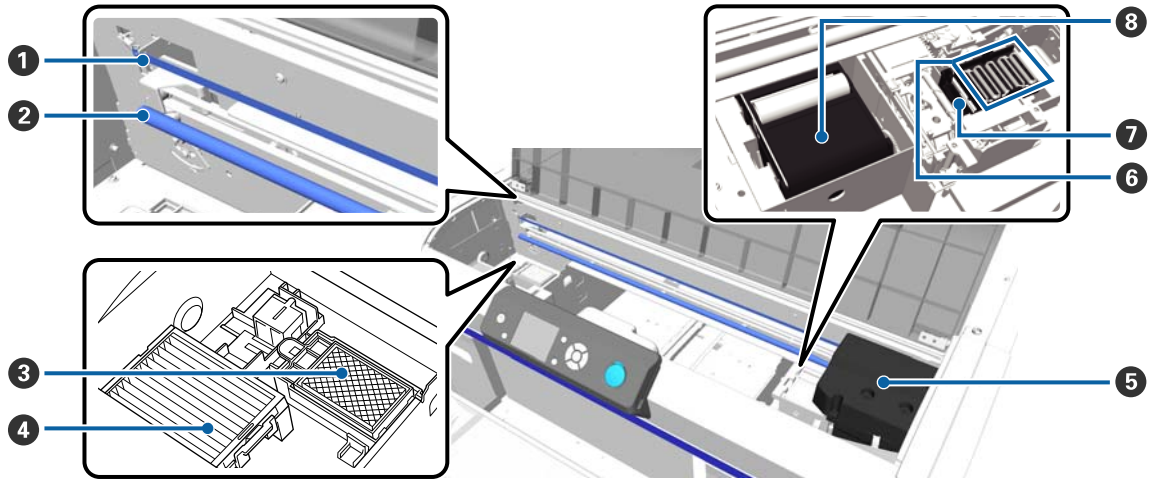

- ① Scale
- ② Carriage shaft
- ③ Flushing pad
- ④ Air filter
- ⑤ Print head
- ⑥ Anti-drying caps
- ⑦ Suction cap
- ⑧ Wiper unit

Rear section

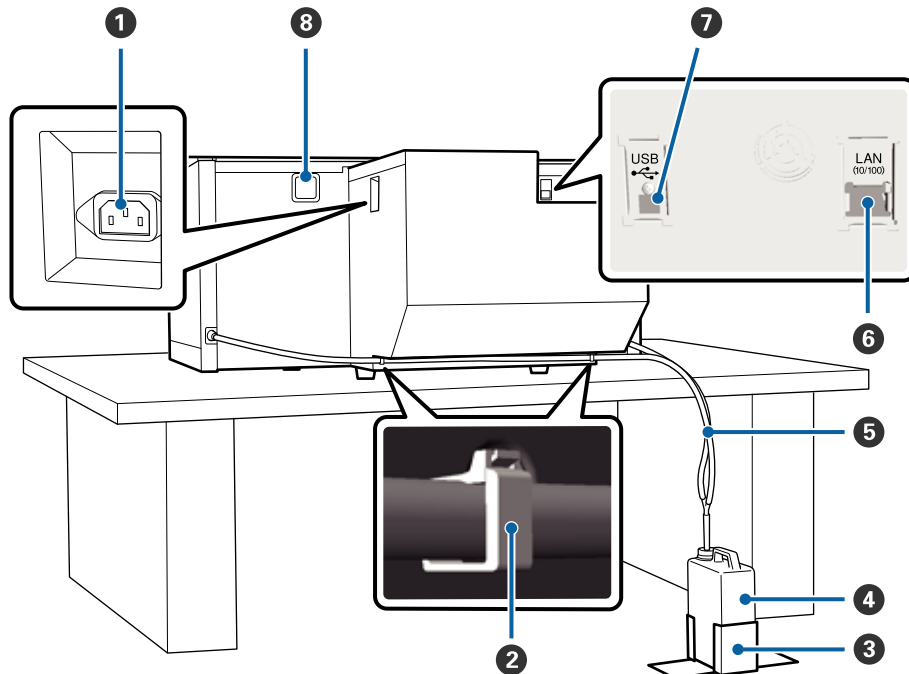

- ① AC inlet
- ② Tube clamp
- ③ Waste ink bottle holder
- ④ Waste ink bottle
- ⑤ Waste ink tube
- ⑥ LAN port
- ⑦ USB port
- ⑧ Air inlet

Basic Printing

Preparation

To print on a T-shirt using this printer, you need the following devices and parts.

Prepare genuine ink cartridges, pre-treatment liquid, and a platen for use with this printer.

 [“Options and Consumable Products” on page 50](#)

Device for Fixating Ink

You need one of the following devices to fixate the ink after printing. Use as required.

Heat press (commercially available)

As well as fixating the ink, this is also used to remove creases from T-shirts before printing starts and to fixate the pre-treatment liquid when using White ink. The heat press needs to be larger than your platen and to be able to sustain 170 °C or more for 90 seconds. We recommend a heat press with a foam sheet or mat to allow the steam to escape. If these are not supplied, you need to acquire them beforehand.

Oven (commercially available)

This can only perform ink fixation. When using White ink, make sure you use a heat press as you need to fixate the pre-treatment liquid.

Under Normal Usage

Platen

A standard M-size platen is supplied. As well as this M-size platen, there are five other types of platens at different sizes available.

 [“Options and Consumable Products” on page 50](#)

Grip Pad Tool

This is used when loading a T-shirt on a grip pad covered platen. We recommend using the grip pad tool supplied to remove slack and creases from the T-shirt you loaded.

T-shirts (commercially available)

We recommend using a 100% cotton, thick fabric with a high weave density.

You can load media with a cotton blend ratio of 100% to 50%. However, we recommend making a test print in advance since the print quality cannot always be guaranteed for some types of fabric.

Sticky tape or a sticky roller (commercially available)

This is used to remove lint from the print surface of the T-shirt before printing.

Hard roller (optional item or commercially available)

This is used to press the fibers flat on the print surface of the T-shirt before printing.

When using commercially available products, make sure you prepare a separate hard roller and pre-treatment liquid roller.

Heat-resistant release sheet (commercially available)

Place this over the T-shirt to prevent any pre-treatment liquid or ink from touching the press side of the heat press.

Prepare silicon paper, fluoro-resin sheets, and so on.

Heat-resistant fabric (commercially available)

Place this on top of and under the T-shirt when using a heat press with a T-shirt being printed on near the seams, such as the sleeves. We recommend using the same type of fabric as the T-shirt.

Items for Use in Pre-treatment (Only when Using White Ink)

This is necessary when printing using White ink. You can attain the following results by applying pre-treatment liquid before printing.

- Develops White ink creating a more vivid color.

Basic Printing

- ❑ Improves the color development on the White ink.

Pre-treatment liquid (consumable)

Apply the diluted pre-treatment liquid to the T-shirt with a roller or spray bottle before printing.

Pure water (commercially available)

Dilutes the pre-treatment liquid.

Pre-treatment liquid roller (option or commercially available)

This is used to apply pre-treatment liquid to the T-shirts. Using a roller makes it easier to apply the liquid better to uneven areas such as pockets, and wastes less liquid from splashing and so on compared to sprays. However, if the liquid is not applied evenly, the whiteness may not be sufficient or it may uneven.

The optional pre-treatment roller set consists of the roller and handle (roller grip), and a tray.

We recommend the following items when using commercially available products.

Roller: Short bristled, polyester fiber with excellent absorption and release of liquid (such as a paint roller).

Roller handle: Made of rust-resistant aluminum

You also need a separate tray to allow the pre-treatment liquid to soak into the roller.

Spray bottle (commercially available)

This is used to apply pre-treatment liquid to the T-shirts.

This allows you to apply quickly and easily compared to a roller. However, when spraying a mist on to T-shirts, the pre-treatment liquid is often wasted as it sprays beyond the edges of the T-shirt, you also need to secure a space to use the spray.

Prepare a spray bottle that allows you to spray a fine mist (we recommend an electric spray bottle).

Basic Printing

Overview

This section explains the basic workflow from preparing a T-shirt before printing to post-treatment after printing.

The following shows the procedure for sending a job from the Garment Creator supplied to the printer and then printing on a T-shirt. The printer also allows you to print by connecting a USB memory containing a saved job.

 [User's Guide \(Online Manual\)](#)

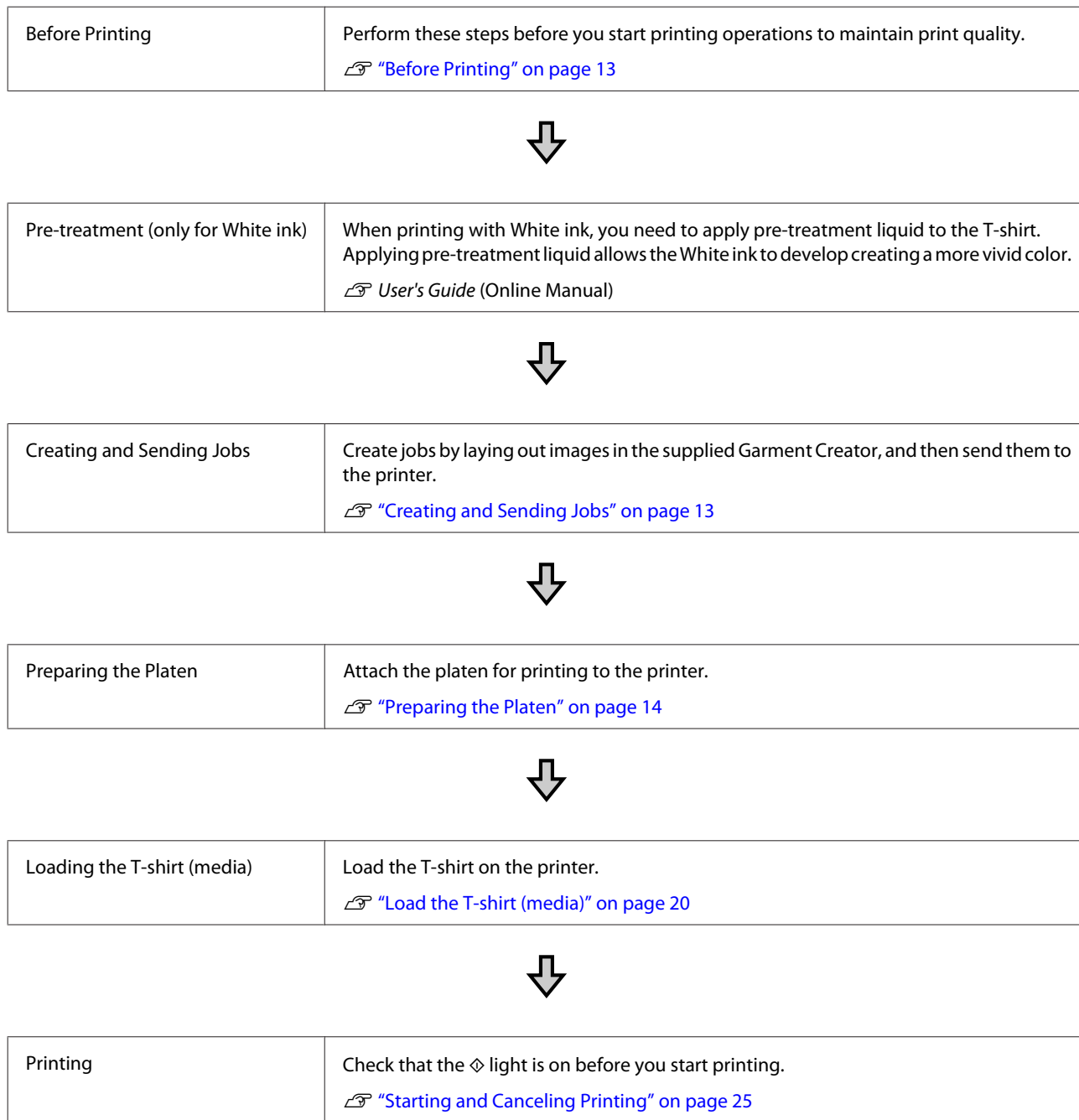

Basic Printing

Removing the T-shirt (media)	Remove the T-shirt from the printer.
------------------------------	--------------------------------------



Post-treatment	Fixate the ink to the T-shirt.  "Fixating the Ink" on page 26
----------------	-------------------------------------------------------------------------------------------------------------------------------------------------------------------

Before Printing

To maintain good print quality, perform the following inspection before starting printing operations each day.

Check the amount of ink remaining:

Check the amount of ink remaining on the screen, and replace with a new ink cartridge when ink is expended. When ink is running low, we recommend replacing the cartridge as soon as possible.

If an ink cartridge runs out while printing, you can continue printing after replacing the ink cartridge. However, if the ink cartridge is replaced during a print job, the tone of the print results may differ depending on the drying conditions.

 [“Shaking and Replacing Ink Cartridges” on page 42](#)

Print Pattern

Print a check pattern to check for clogged nozzles.

Perform head cleaning if parts of the pattern are faint or missing.

Print a Check Pattern  [“Checking for clogged nozzles” on page 38](#)

Head Cleaning  [“Cleaning the print head” on page 40](#)

Creating and Sending Jobs

You cannot print directly from commercially available software.

To print jobs created on commercially available software, send the jobs to the printer using the software supplied (Garment Creator).

Workflow for Creating and Sending Jobs

Creating Images for Printing

Create an image using commercially available software such as Photoshop, Illustrator, and so on.



Creating Jobs

Start Garment Creator and load the image you want to print, and then make the following settings to create the job.

- Set the position and size of the image according to the platen size used for printing.
- Set the Print Quality and so on



Sending Jobs

Send the job from Garment Creator to the printer.

When receiving a job on the printer, the message **Place shirt and press  to start printing.** is displayed, place the T-shirt on the platen and then print.

For more details on creating and sending jobs, see the online help for Garment Creator.

Basic Printing

Notes on Receiving Jobs

Only the following operations are possible while receiving jobs. If buttons do not respond when operating the control panel, the printer may be receiving a job; wait for a while and then try again.

- Canceling a job
- Moving the movable base (platen)
- Turning off the power

Note:

- After canceling a job, it takes a while before the printer is ready to print again.*
- It takes a while to turn off the printer after performing the power off operation. Also, jobs that have been received are deleted.*

Preparing the Platen

This section explains how to prepare the L, M, S, and XS size platens. See the following for details on preparing the sleeve platen or the medium grooved platen.

 [User's Guide \(Online Manual\)](#)

The following explains preparations for two points.

Grip pad covered platen (first time only)

We recommend attaching a grip pad to the platen supplied with the printer or the optional S, M, or L size platens.

Using a grip pad covered platen prevents the T-shirt (media) from moving around easily during printing which reduces print misalignments.

The next section explains how to attach the grip pad to the platen.

The printer comes with a grip pad that you can attach to a platen. For the optional S, M, and L size platens, purchase commercially available grip pad and attach them to the platens.

Do not attach grip pad to the XS size, sleeve, and medium grooved platens.

When using platens without attaching a grip pad, make sure you load the platen using the platen frame supplied.

 [User's Guide \(Online Manual\)](#)

Note:

When printing on thin fabric with a polyester blend ratio of 50% or more using a grip pad covered platen, the grip pad may be soiled with ink.

Replacing Platens and Removing/Attaching Spacers

There are six platens available according to the size of the T-shirt and the area you want to print. When changing the size or area of the T-shirt being printed on, make sure you replace the platen with the appropriate platen in advance.

Basic Printing

Depending on the thickness of the fabric being printed on, you also need to attach/remove the spacers in advance to adjust the platen height to the appropriate position.

 [“Replacing Platens and Removing/Attaching Spacers” on page 17](#)

Attaching/Removing a Grip Pad

Grip pads are consumable items. If it gets dirty, purchase a new pad and replace it.

 [“Options and Consumable Products” on page 50](#)

You can check the procedure in a video on YouTube.

[Epson Video Manuals](#)

Attaching the Pad

- 1 Only peel off one section on the back of the grip pad as shown in the illustration.

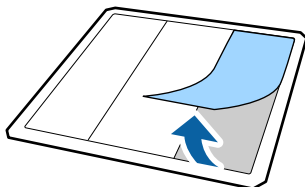

- 2 Place the grip pad on a flat surface with the back side facing up, and then place the platen in the center.

Make sure it is in the center so that the position does not shift from the grip pad.

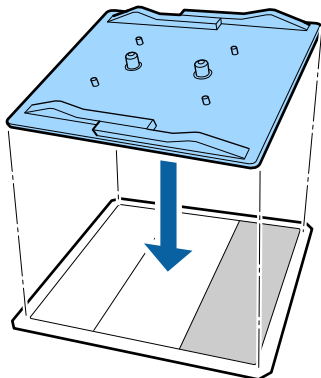

- 3 Gently hold the section that was peeled off the pad, and then stick the grip pad.

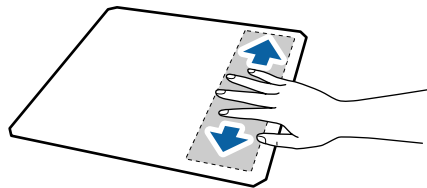

- 4 Peel off all of the other sections on the back of the grip pad as shown in the illustration.

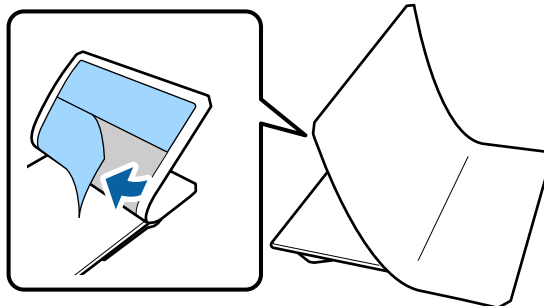

- 5 Stick it from the end that is already stuck, as shown in the illustration.

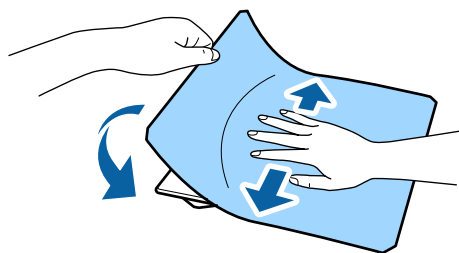
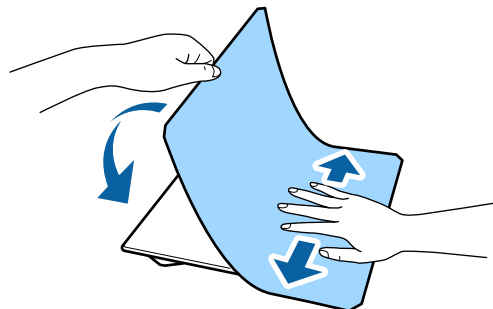

- 6 Peel off all of the sections around the edges on the back of the grip pad as shown in the illustration.

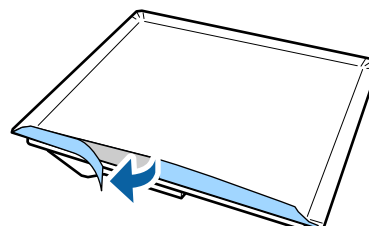

Basic Printing

- 7** Fold over the long edges of the grip pad and stick them to the back of the platen without allowing the pad to loosen or sag.

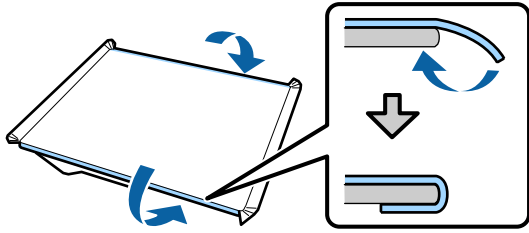

- 8** Fold over and stick all of the corners of the grip pad.

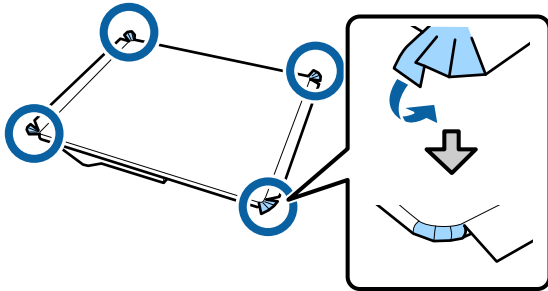

- 9** Fold over and stick the short edges.

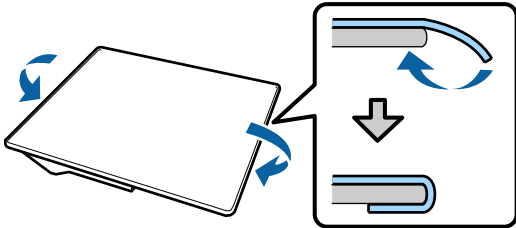

- 10** Turn the platen over and press down the folded edges of the grip pad to stick them firmly in place.

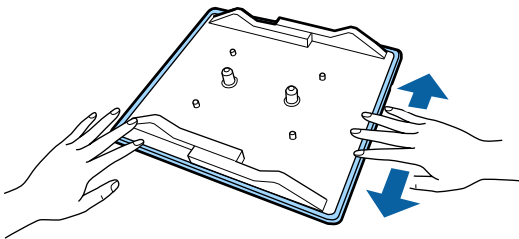

Removing the Sheet

Important:

- ❑ Do not apply hot air such as a drier to soften the glue. Failure to observe this precaution could result in deformed parts.
- ❑ Do not use organic solvents such as alcohol. Failure to observe this precaution could result in discoloration, warping, or damage to parts.

- 1** Place the platen on a flat surface with the back side facing up.

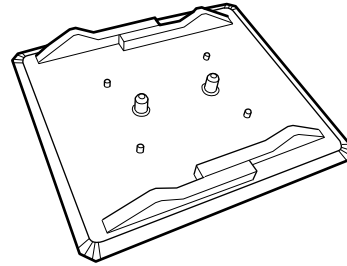

- 2** Peel off the pad that has been folded over the edges.

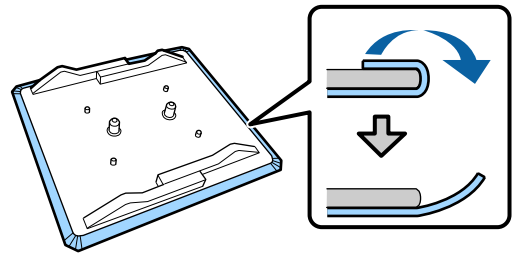

Note:

Pads that have been stuck to the platen for a long time may be hard to peel off. In this case, use a commercially available spatula for peeling off labels.

- 3** Turn it over and press the front of the platen.

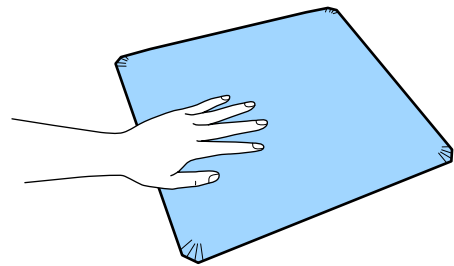

Basic Printing

- 4** Peel off the grip pad from back to front.

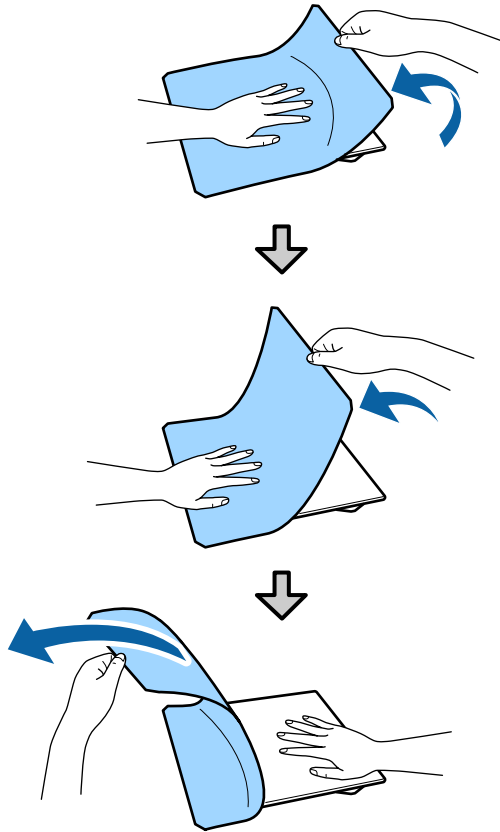

If any glue remains on the platen, soak a soft cloth in a diluted neutral detergent, wring it out thoroughly, and then wipe off the glue.

Replacing Platens and Removing/Attaching Spacers

Prepare a cross-head screwdriver before removing the spacers.

Buttons that are used in the following operations



- 1** Check that the platen is ejected forward.
If it is not ejected, press the  button to move the platen forward.

- 2** Turn off the printer.

- 3** Grip the left and right of the platen, and lift it straight up to remove it.

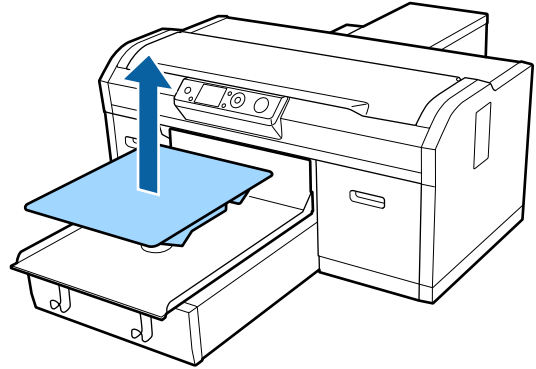

- 4** Check the condition of the spacers.
The type and number of spacers to be removed differs as shown below depending on the type of platen installed and the thickness of the fabric to be printed on.

The thickness shown in the following table is the total thickness of the fabric placed on the platen.

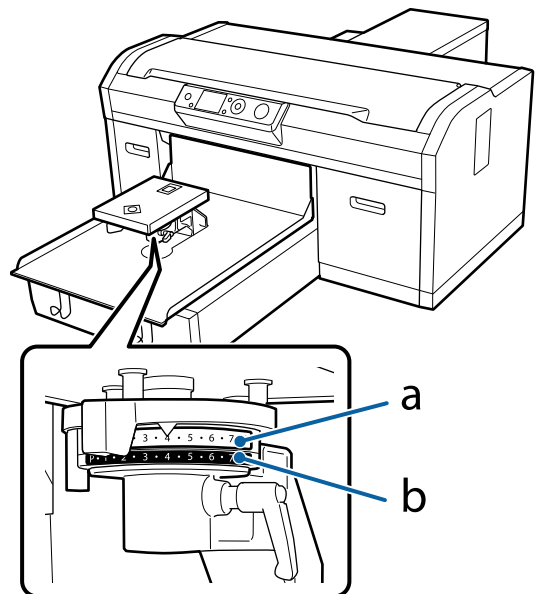

Basic Printing

When using L, M, S, and XS size platens

For T-shirts or sweatshirts with a thickness up to 7.0 mm*

Attach spacers a and b.

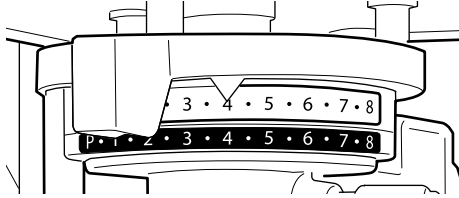

For fabric with a thickness of 5.0 to 13.0 mm*

Attach spacer a only.

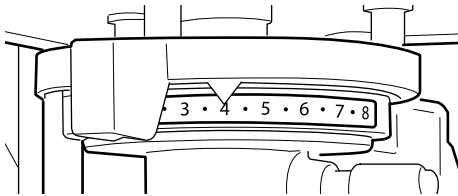

For fabric with a thickness of 9.0 to 17.0 mm*

Attach spacer b only.

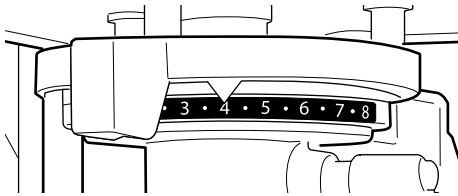

For fabric with a thickness of 15.0 to 24.0 mm*

Remove spacers a and b.

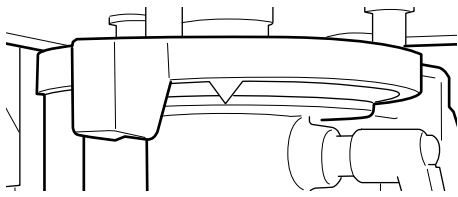

* The values indicated are when using a grip pad covered platen. When using a platen without grip pad attached, the media you are printing on can be 1.0 mm thicker.

If you do not need to change the number of spacers, go to step 13.

If you do need to change the number of spacers, go to step 5.

5 Loosen the fixing lever.

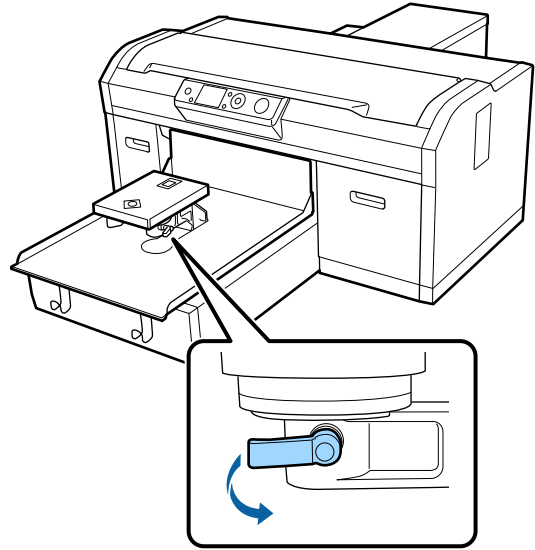

6 Use the cross-head screwdriver to remove the screws securing the platen installation plate.

Make sure you keep the removed screws in a safe place as you need them when attaching spacers a and b.

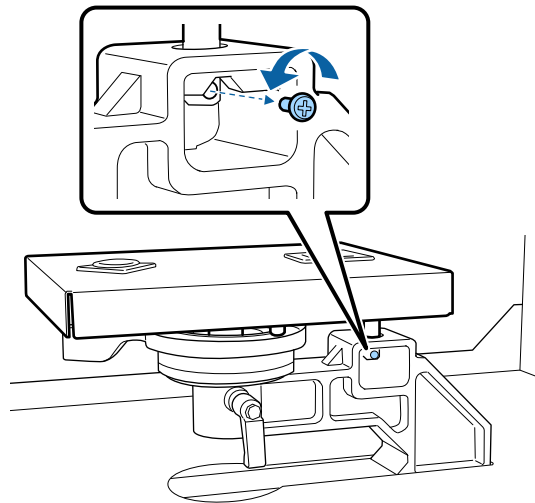

7 Remove the platen installation plate.

! Important:

Make sure you do not drop the platen installation plate as it is a precision part. If it is dropped, the part could be deformed and may not function correctly.

Basic Printing

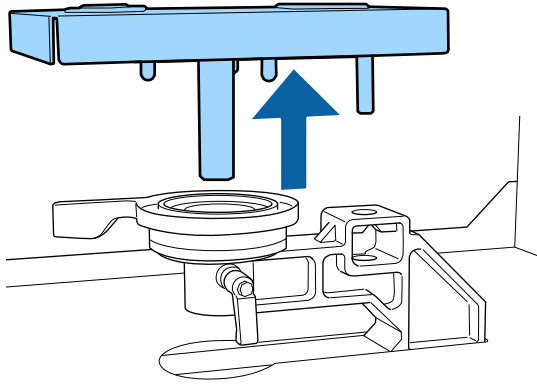

8 Remove the platen gap adjustment lever.

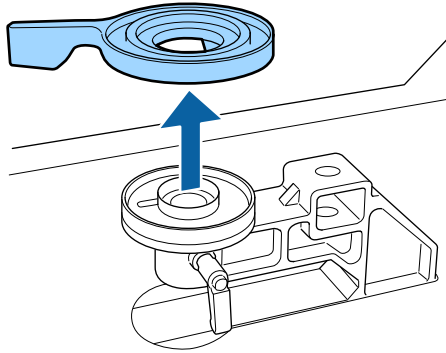

9 Change the status of the spacer in step 4 according to the installed platen and the thickness of the fabric to be printed on.

Removing

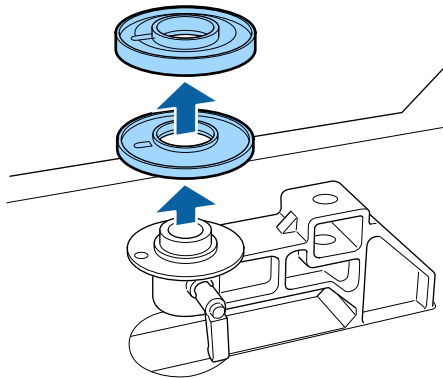

Attaching

Align the protruding section of the spacer with the hole as shown below. If this is not installed in the correct direction, the platen gap adjustment lever does not move.

There is no particular stacking order when installing both spacers.

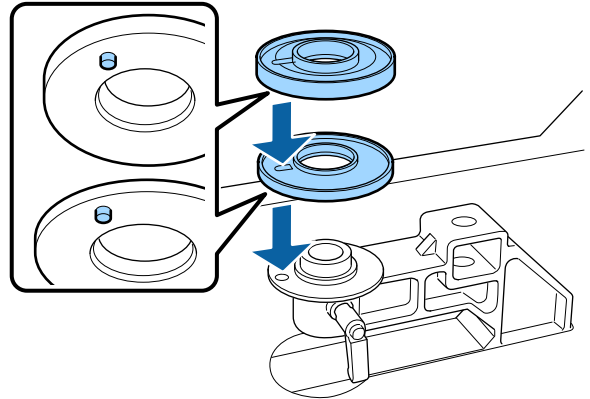

10 Install the platen gap adjustment lever in the direction shown below.

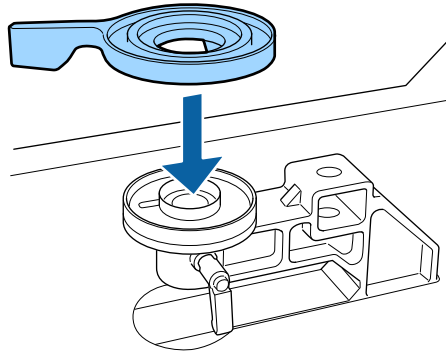

11 Return the platen installation plate.

Only tighten the screws that you removed in step 6 when you have installed two spacers.

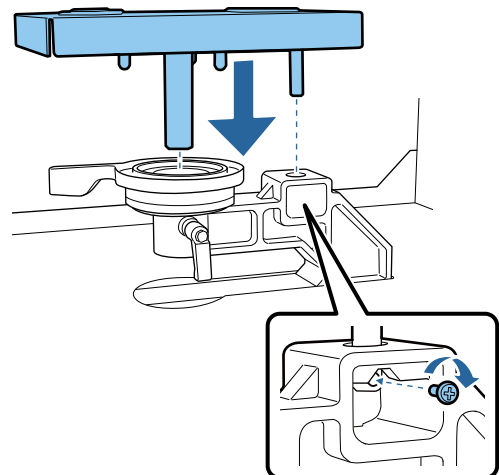

Basic Printing

- 12** Tighten the fixing lever to secure the platen gap adjustment lever.

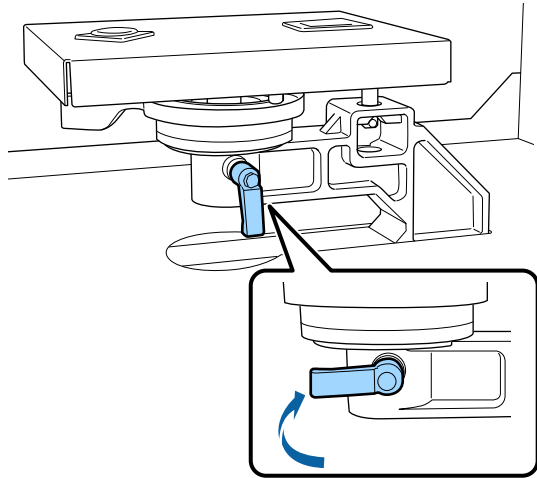

- 13** Make sure the axes of the replacement platen fit into the holes.

The L, M, S, and XS size platens do not have front and rear orientations.

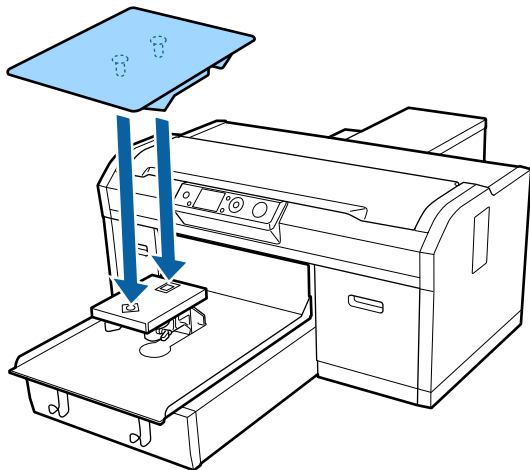

After replacing the platen with a different size, we recommend you correct print misalignment (Head Alignment).

[User's Guide \(Online Manual\)](#)

Load the T-shirt (media)

This section explains how to install the L, M, S, and XS size platens.

See the User's Guide for details on installing the sleeve and medium grooved platens.

[User's Guide \(Online Manual\)](#)

If you notice any creases on the T-shirt, use the heat press to iron them out before you start printing.

When attaching an L, M, or S size grip pad covered platen, do not use the frame supplied as you cannot secure the T-shirt correctly.

When using an L, M, or S size platen without a grip pad, an XS size platen, sleeve platen, or medium grooved platen, use a frame to secure the T-shirt.

How to Load Using a Frame [User's Guide \(Online Manual\)](#)

You can check the procedure in a video on YouTube.

[Epson Video Manuals](#)

Buttons that are used in the following operations

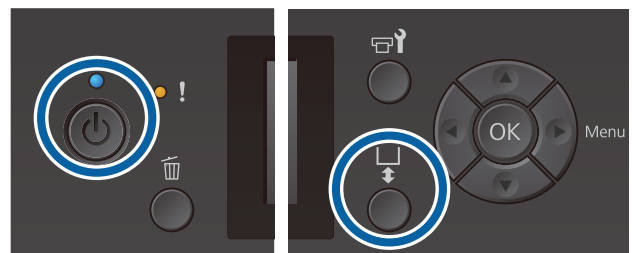

- 1** Press the button to turn on the printer.
- 2** Check that the platen is ejected forward.
If it is not ejected, press the button to move the platen forward.

Basic Printing

- 3** Load the T-shirt so that the shoulders are at the front.



- 4** Smooth out the print surface so that it is flat.



- 5** Remove any lint from the printing surface, and press the fibers flat.

There may be lint on the T-shirt if you have not applied pre-treatment liquid. Remove the lint using the sticky tape or roller and press the fibers flat using the hard roller. Lint and fibers may stick to the print head and stain other areas.

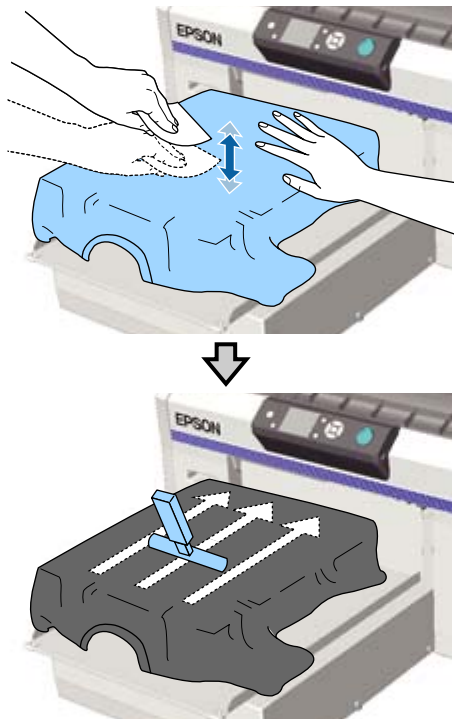

- 6** Remove any slack or creases from the printing surface and make it flat.

When using a grip pad covered platen, we recommend that you use the grip pad tool supplied to flatten the printing surface. This makes it easier to perform operations and produces a flattened finish.

However, do not use the grip pad tool if it catches on the surface of the fabric. Print quality may decline, or the media may be damaged.

Media with pre-treatment liquid may stick to the bottom of the grip pad tool in the following situations.

- When the pre-treatment liquid has not dried sufficiently
- When the pre-treatment liquid has dried but the media was left for a long time in a location with high humidity
- When too much pre-treatment liquid has been applied

Also, depending on the type of fabric, the grip pad tool may stick even without pre-treatment liquid.

Basic Printing

When Using the Grip Pad Tool

Press the T-shirt lightly with the grip pad tool and move it vertically and horizontally from the edges as shown in the following illustration. Repeat this step 2 to 3 times to remove any slack or creases and make the printing surface flat.

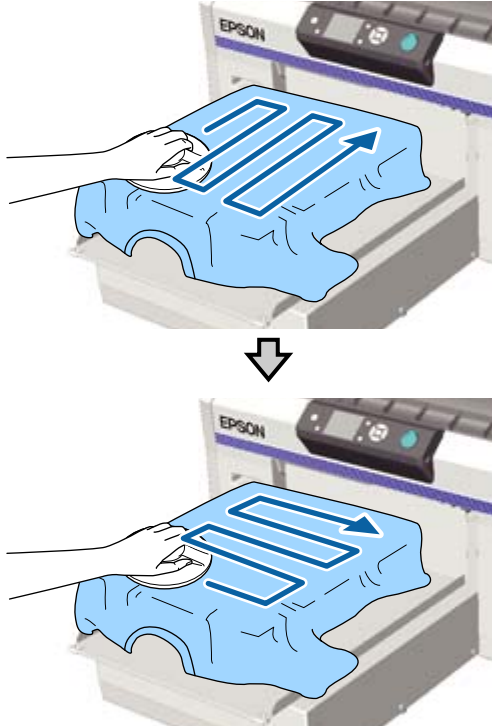

Note:

If you use the grip pad tool on media coated in pre-treatment liquid, some pre-treatment liquid may stick to the bottom of the grip pad tool. The next time you use the grip pad tool, make sure you wipe off any pre-treatment liquid stuck to the bottom of the grip pad tool with a damp cloth.

When Not Using the Grip Pad Tool

Use your hand to smooth out any creases and slack to make the printing surface flat.



! Important:

The printer detects the highest part of the print surface and adjusts the height. If there are any creases or slack remaining as shown in the illustration below, the distance between the print head and the print surface may increase and print quality may decline. Flatten the T-shirt so that there are no creases or sagging.

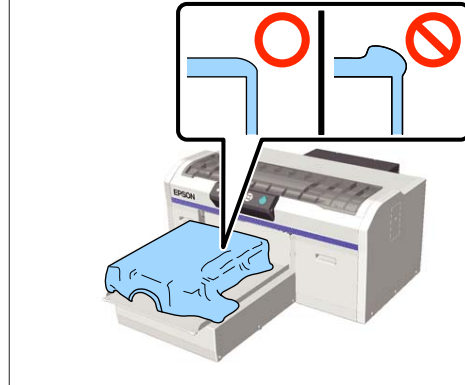

7

Tuck in the T-shirt so that it does not drape over the movable base.



Adjusting the Platen Gap

The platen gap is the distance between the print head and the T-shirt (media).

Failure to use platen gap adjustment to adjust to the correct distance may cause print quality to decline or stain the inside of the printer with ink.

The larger the value on the scale indicated by the platen gap adjustment lever, the lower the platen is and the wider the distance from the print head. The following workflow explains how to perform adjustments.

Basic Printing

Adjust the gap to the narrowest point

The platen gap is gradually narrowed by slowly changing from the guided scale to the smaller scale one step at a time.



Check the Platen Height Error

If the platen gap is narrowed beyond the limit, this error is displayed.



Set the platen gap to a suitable value

The position at which the width of the platen gap returns from the second scale to the scale with larger values at which the error is displayed is a suitable value.

Buttons that are used in the following operations

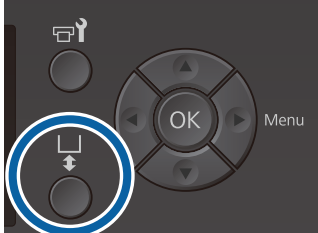

- 1 Check that the platen is ejected forward.
If it is not ejected, press the  button to move the platen forward.

- 2 Loosen the fixing lever under the platen.

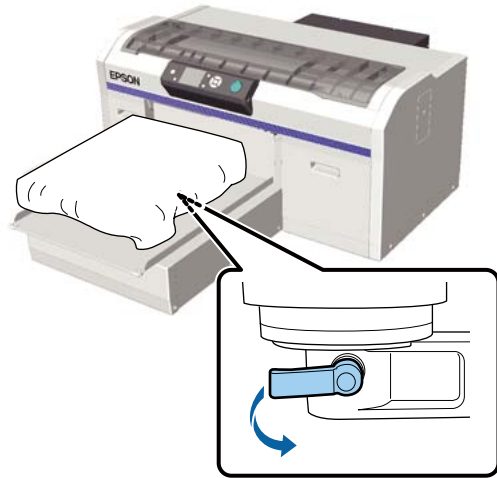

- 3 Move the platen gap adjustment lever to match the scale to the adjustment start position.

When printing on T-shirts using L, M, S, or XS size platens (also with spacers a and b installed)

- When a grip pad covered platen is installed:
Adjust to 4.

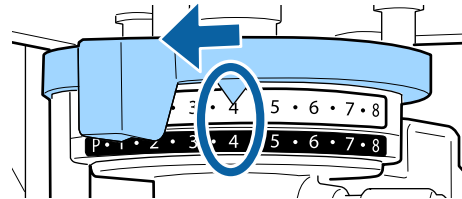

- When a platen without grip pad is installed:
Adjust to 3.

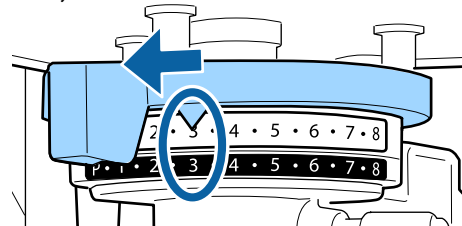

When printing on sweatshirts or thick fabric, and the spacer installation status is anything except for the above

Adjust to 8.

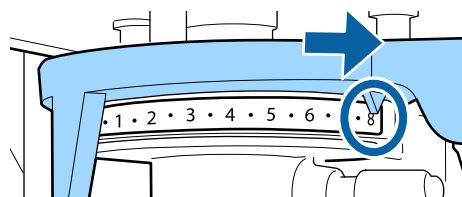

Basic Printing

If you have worked up to step 6 and then return to step 1 to re-adjust the platen gap, move the platen gap adjustment lever by one scale to the smaller values.

Note:

If you remove both spacers, you cannot check the scale. In this situation, the position you move the platen gap adjustment lever to at the far right is position 8.

When re-adjusting, adjust the platen gap adjustment lever by one scale at a time making sure you can feel it click.

- 4** Tighten the fixing lever, and then secure the platen gap adjustment lever.

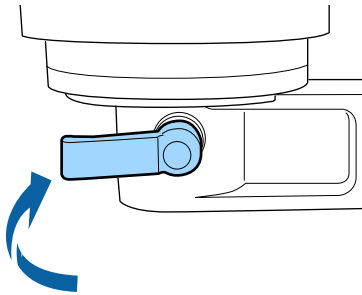

Note:

- Print quality may decline if you do not tighten the fixing lever.
- You can adjust the fixing lever to any angle. Adjust the angle of the lever if it is difficult to see the scale, or if it is difficult to pass the fabric of the T-shirt underneath. When adjusting, change the position while pulling the lever toward you.

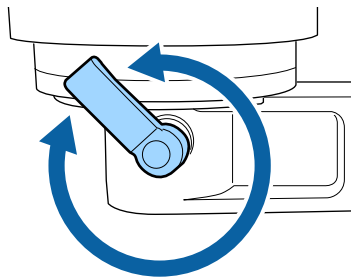

- 5** Press the  button to move the platen into the printer.

- 6** Check if **Platen Height Error** is displayed on the control panel.

When the error is displayed

Go to step 7.

When the error is not displayed

Repeat the following steps until the error is displayed.

Return to step 1 and when you reach step 3, move the platen gap adjustment lever by one scale to the smaller values. The platen rises reducing the gap. Continue to step 6, and check if an error is displayed.

- 7** Set the platen gap to a suitable value

Return to step 1 and when you reach step 3, move the platen gap adjustment lever by two scales to the smaller values.

Continue to step 6, and if the error is not displayed, adjustment is complete.

Starting and Canceling Printing

Starting

- 1 When receiving the job is complete, the message **Place shirt and press  to start printing.** is displayed on the screen.

When receiving the job is complete, the  light also turns on.



Preview display

When you press the  button while the message is displayed, a preview of the job is displayed.



- 2 Check that the T-shirt is loaded, and then press the  button.

Note:

When you press the  button while the message is displayed, the maintenance menu is displayed and you can select **Nozzle Check** or **Head Cleaning** without canceling the received job. You can check if nozzles are clogged and clean the head before printing starts or while printing multiple copies.



If you select **Nozzle Check**, the check pattern is printed at the platen size displayed on the control panel screen.

Canceling

Use this when you want to cancel printing, or to cancel a job that is being received by the printer.

- 1 Press the  button.



- 2 Press the / buttons to highlight **Yes**, and then press the **OK** button.

Printing or receiving stops immediately when the button is pressed, and the job is deleted.

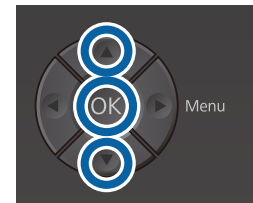

Basic Printing

Fixating the Ink

After printing, the T-shirt is processed in a heat press or oven to fixate the ink.

Precautions when Fixating the Ink

- ❑ If you use a heat press with a T-shirt (media) that has printing near the seams such as the sleeves, fixation may not be performed correctly as ink is not heated sufficiently due to the difference of levels in the seams.
We recommend placing a heat-resistant fabric above and below the T-shirt and applying pressure as shown below to reduce the difference in levels.

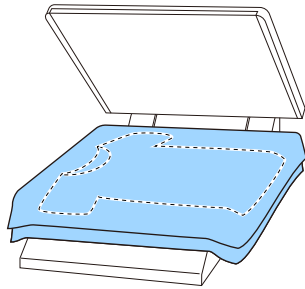

- ❑ If the ink is not fixated sufficiently, colors may come out in the wash or when rubbing against something.
- ❑ If the T-shirts (media) have plastic buttons or zippers, we recommend that you first confirm whether or not they will be damaged before using the heat-press.

Fixating conditions

The conditions required for fixating differ as shown below according to the heat press or oven.

Use the following values as a guide. The optimum conditions vary depending on the type of heat press or oven, and the amount of ink.

Heat press

Temperature	Time	Pressure ^{*1}
170 °C	45 seconds ^{*2}	4.2 N/cm ²

*1 The optimum conditions vary depending on the type of heat press such as the manual adjustment type. Be sure to test the ink fixation result in advance to find the right pressure.

*2 Images larger than A4 that have White ink may take longer than 45 seconds to dry. Try extending the time up to 90 seconds while checking if the ink is dry.

Oven

Because the optimum conditions vary depending on the oven, test and check the ink fixation result in advance to determine the temperature and duration.

Type of Oven	Temperature	Time
Batch type	160 °C	3.5 to 5 minutes ^{*2}
Conveyor type	160 °C ^{*1}	3.5 to 4.5 minutes ^{*2}

*1 Temperature of the fixating surface of the T-shirt. Not the internal temperature. If the surface of the T-shirt exceeds 180 °C, the T-shirt and the print surface may change color.

*2 Images that have White ink require the maximum fixating time (batch type: 5 mins., conveyor type: 4.5 mins.).

Maintenance

When to Perform Various Maintenance Operations

To maintain the print quality of the printer, you need to perform cleaning and replace consumables.

If maintenance is not performed, print quality may decline, the printer's service life may be reduced, or you may be liable for the cost of any repairs. Always perform maintenance when a message is displayed on the screen.

Cleaning Locations and Cleaning Timing

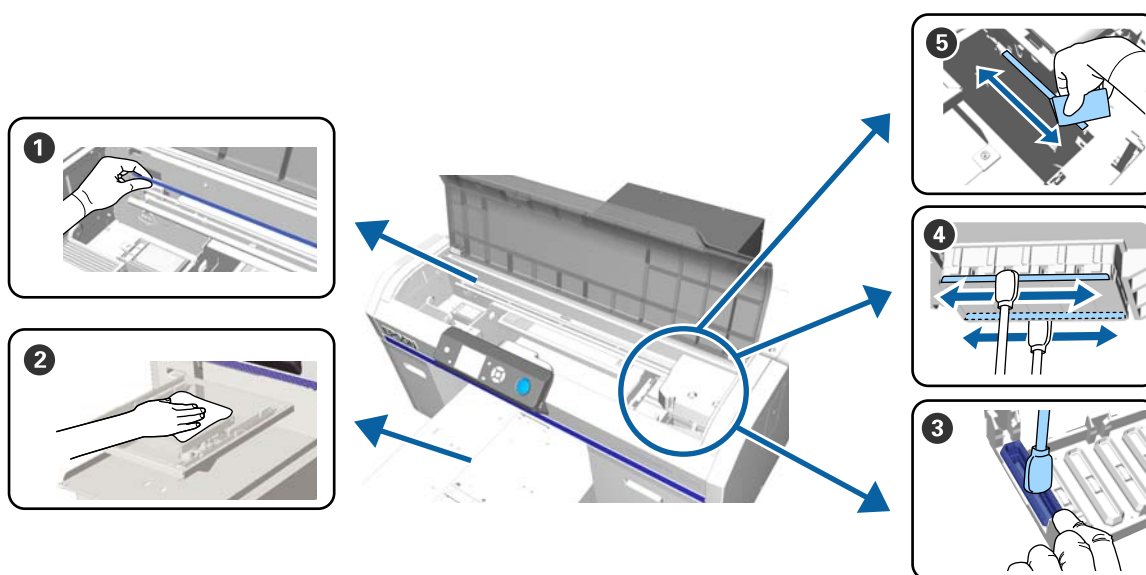

When to perform	Component to be cleaned
See manual to clean scale and change air filter. is displayed	<p>① Scale</p> <p>🔗 "Cleaning the scale and replacing the filter" on page 36</p> <p>You can check the procedure in a video on YouTube.</p> <p>Epson Video Manuals</p>
If a platen without grip pad is soiled	<p>② Clean the platen without grip pad</p> <p>🔗 User's Guide (Online Manual)</p>
<p><input type="checkbox"/> When one of the following messages is displayed*</p> <p>Do following: Head Cap Cleaning</p> <p>See manual to clean caps.</p> <p><input type="checkbox"/> When there are ink stains on the printing surface of the T-shirt</p>	<p>③ Suction cap</p> <p>🔗 "Cleaning the Suction Cap" on page 33</p> <p>You can check the procedure in a video on YouTube.</p> <p>Epson Video Manuals</p>

Maintenance

When to perform	Component to be cleaned
The printing surface and so on is soiled even when cleaning the caps	<p>④ Clean around print head</p> <p>User's Guide (Online Manual)</p> <p>You can check the procedure in a video on YouTube.</p> <p>Epson Video Manuals</p>
When printing is not performed normally even after head cleaning	<p>⑤ Clean edges of the metal</p> <p>User's Guide (Online Manual)</p>

* If this message is displayed frequently, contact your dealer or Epson support.

Locations of Consumables and Replacement Timing

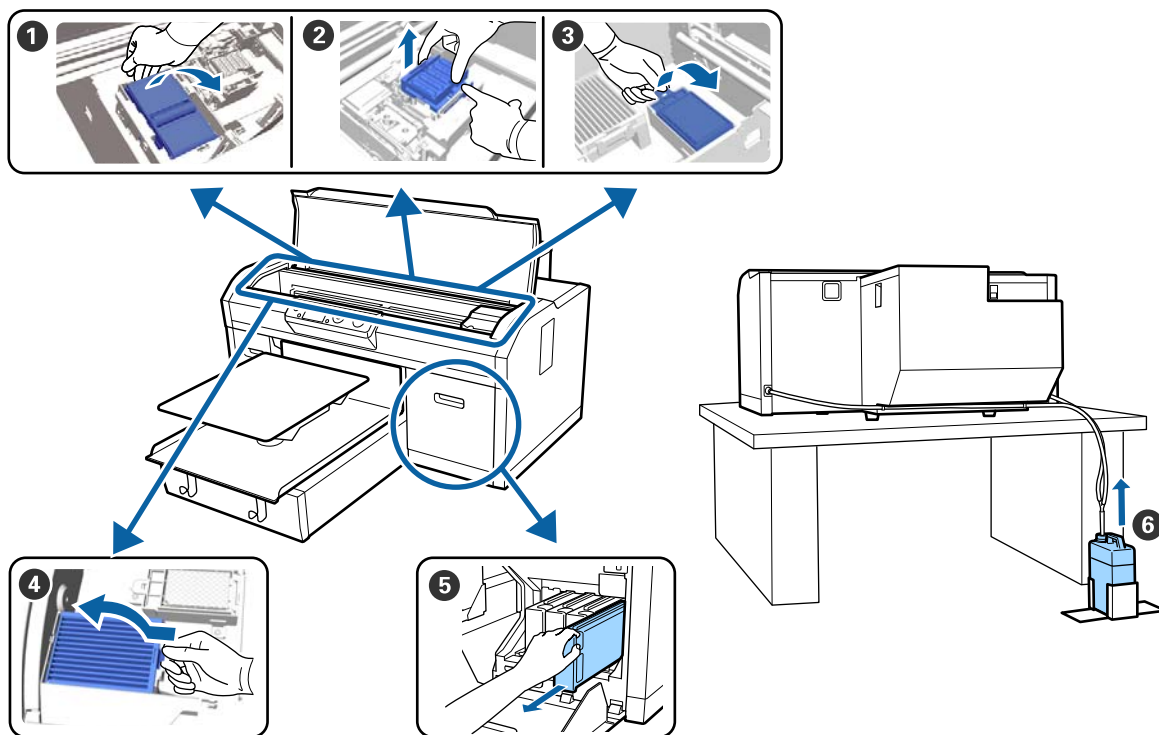

When to perform	Component to be replaced
When a message indicating that an item needs to be prepared or replaced is displayed	<p>① Wiper unit</p> <p>② Anti-drying caps</p> <p>③ Flushing pad</p> <p>"Replacing the Head Cleaning Set" on page 46</p> <p>You can check the procedure in a video on YouTube.</p> <p>Epson Video Manuals</p> <p>⑥ Waste ink bottle</p> <p>"Disposing of Waste Ink" on page 44</p>

Maintenance

When to perform	Component to be replaced
See manual to clean scale and change air filter. is displayed	<p>④ Air filter*</p> <p>“Cleaning the scale and replacing the filter” on page 36</p> <p>You can check the procedure in a video on YouTube. Epson Video Manuals</p>
Ink Low is displayed, as soon as you can	<p>⑤ Ink cartridge</p> <p>“Shaking and Replacing Ink Cartridges” on page 42</p>

* Replace the air filter when cleaning the scale.

Other maintenance

When to perform	Operation
Remove and shake WH ink is displayed	<p>Shake White ink cartridge</p> <p>“Shaking” on page 42</p>
Once a month	<p>Shake color ink cartridges</p> <p>“Shaking” on page 42</p>
<input type="checkbox"/> When checking if nozzles are clogged <input type="checkbox"/> When checking which colors are clogged <input type="checkbox"/> Horizontal stripes or tint unevenness (banding) are appeared.	<p>Checking for clogged nozzles</p> <p>“Checking for clogged nozzles” on page 38</p>
<input type="checkbox"/> When printouts are blurred or parts are missing <input type="checkbox"/> When a clog is found after checking for clogged nozzles	<p>Cleaning the print head</p> <p>“Cleaning the print head” on page 40</p>
When the printouts are grainy or out of focus	<p>Head Alignment Offset Head Alignment</p> <p>User's Guide (Online Manual)</p>
When changing the ink mode	<p>Change the ink mode</p> <p>User's Guide (Online Manual)</p>
When the printer will not be used for an extended period (and switched off)	<p>Pre-Storage Maint.</p> <p>User's Guide (Online Manual)</p>
<input type="checkbox"/> When nozzles remain clogged even after cleaning the print head several times <input type="checkbox"/> When there is not enough white in white ink mode, or when white results in uneven print results	<p>Tube cleaning</p> <p>User's Guide (Online Manual)</p>

Maintenance

Preparation

Ready the following items before beginning cleaning and replacement.

When the supplied parts have been completely used, purchase new consumables.

Prepare genuine parts when replacing ink cartridges or performing maintenance.

 [“Options and Consumable Products” on page 50](#)

Protective eye-wear (commercially available)

Protects your eyes against ink and ink cleaner.

Tweezers

Use this to remove lump or film of waste liquid.

Maintenance kit (supplied with the printer)

Use this to clean around the caps and print head.

The set contains gloves, cleaning sticks, ink cleaner, and a cup.

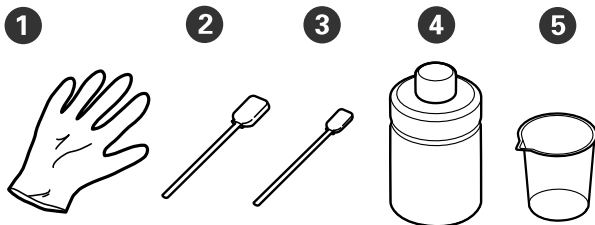

- ① Gloves (x4)
- ② Cleaning stick (wide) (x25)
- ③ Cleaning stick (narrow) (x25)
- ④ Ink cleaner (x1)
- ⑤ Cup (x1)

Metal or plastic tray (commercially available)

Use this to hold used cleaning sticks, removed parts, or to prevent ink from soiling the printer when cleaning around the print head.

Air filter (consumable)

When cleaning the scale, use the cleaning cloth supplied with the air filter.

Soft cloth

This is used to clean the edges of the metal and to clean platens without grip pad.

Cautions when operating

 **Caution:**

- Always wear protective eyewear, gloves, and a mask when working. Should any waste ink or ink cleaner come into contact with your skin or enter your eyes or mouth, immediately take the following actions.*
 - If fluid adheres to your skin, immediately wash it off using large volumes of soapy water. Consult a physician if the skin appears irritated or is discolored.*
 - If fluid enters your eyes, rinse immediately with water. Failure to observe this precaution could result in bloodshot eyes or mild inflammation. If problems persist, consult a physician.*
 - If any enters your mouth, consult a physician immediately.*
 - If fluid is swallowed, do not force the person to vomit and consult a physician immediately. If the person is forced to vomit, fluid may get caught in the trachea which can be dangerous.*
 - Store ink cartridges, waste ink, ink cleaner, and Cleaning cartridges out of the reach of children.*
 - Remove the T-shirt from the printer before starting cleaning.
 - Do not touch any parts or circuit boards other than the parts that need to be cleaned. It may cause a malfunction or decline of the print quality.
 - Always use new cleaning sticks. Reusing sticks may soil the parts you are trying to clean.
 - Do not touch the tip of the cleaning stick with your hand. Oils on your hand may compromise the cleaning ability.
 - Do not use organic solvents such as alcohol for cleaning. Only use water when instructed to do so. Mixing ink, water, and organic solvents may cause solidifying and malfunctions to occur. When mixed together, organic solvents could result in discoloration, warping, or damage to parts.
- Touch a metal object before starting operations to disperse any static electricity.

Maintenance

Using ink cleaner

The ink cleaner is used to clean the following parts.

Do not use it on any other parts as this could damage the parts.

Parts you can clean

- When cleaning the suction cap
Dampen a cleaning stick with ink cleaner to use it.
- When cleaning around the suction cap
If there are ink stains that cannot be removed by wiping with a dry cleaning cloth, dampen a cleaning stick with ink cleaner and wipe it.
- When cleaning the scale
Dampen a cleaning cloth in ink cleaner to use it.
- When cleaning around the print head
Dampen a cleaning stick with ink cleaner to use it.

Important:

- This should only be used to clean the suction caps, around the suction caps, scale, and around the print head.*
- Depending on the usage and storage environment, the ink cleaner may change color after opening.*
- If you notice that the ink cleaner has changed color or emits a bad odor, stop using the cleaner and open a new maintenance kit.*
- Make sure you close the lid securely after use, and avoid storing in locations subject to high temperatures, high humidity, and direct sunlight.*

1

Remove the lid from the ink cleaner.

2

Pour an appropriate amount of ink cleaner into the cup supplied with the maintenance kit.

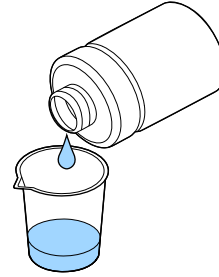

3

Let the ink cleaner soak into the cleaning stick or cleaning cloth.

Make sure that ink cleaner does not drip from the cleaning stick or cleaning cloth.

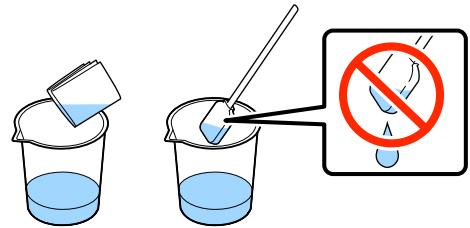

Disposal of used consumables

Disposal

The following used parts with adhered ink or pre-treatment liquid are classified as industrial waste.

- Cleaning stick
- Cleaning cloth
- Ink cleaner
- Waste ink
- Waste ink bottle
- Wiper unit
- Anti-drying caps
- Flushing pad
- Air filter
- Charging unit

Dispose of used consumables according to your local laws and statutes such as entrusting it to an industrial waste disposal company. In such cases, submit the "Safety data sheet" to the industrial waste disposal company.

You can download it at your local Epson Web site.

Cleaning the Suction Cap

Before starting this procedure, be sure to read the following:

 ["Cautions when operating" on page 31](#)

When it is time to clean the suction cap, the message **Do following: Head Cap Cleaning** is displayed. If you continue to use the printer without cleaning, the nozzles may clog and print quality may decline. Even if the message is not displayed, clean the suction cap if printing surface is soiled with ink.

You can check the procedure in a video on YouTube.

[Epson Video Manuals](#)



Important:



Do not move the print head or the platen manually. A malfunction may occur.

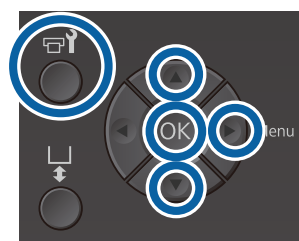

Buttons that are used in the following operations



- 1** Confirm that the printer is on, and then press the  button.

The Maintenance menu is displayed.

- 2** Press the / buttons to select **Head Cap Cleaning**, and then press the  button.

- 3** Press the / buttons to highlight **Yes**, and then press the OK button.

When you press the OK button, the platen and the print head move to the maintenance position.

Maintenance

Note:

After 10 minutes from the start of cleaning the suction caps, a screen will be displayed and a buzzer sounds informing you that 10 minutes have elapsed. Press the **OK** button to continue the cleaning process. After 10 more minutes have passed, the buzzer sounds again.

If the print head is moved out of its home position for more than 10 minutes, the nozzles could easily be clogged. Finish cleaning as soon as possible.

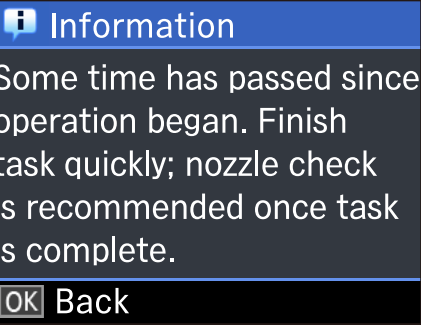

4 Open the printer cover.



5 If there is a lump or film of waste liquid stuck to the suction cap, remove it with the supplied pair of tweezers.

- ! Important:**
- Do not rub the cap section hard. If the cap is damaged, air may leak and the print head may dry or become difficult to clean.
 - Do not use any tweezers such as metal tweezers other than the supplied pair.

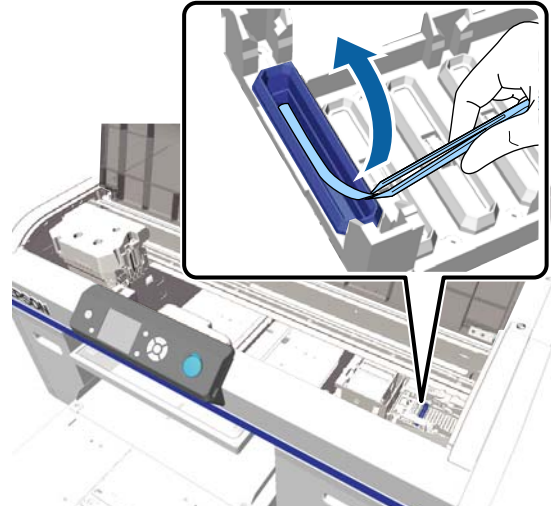

6 Dampen the new narrow and wide cleaning sticks with ink cleaner.

[“Using ink cleaner” on page 32](#)

7 Wipe the inside of the suction cap while rotating the narrow cleaning stick.

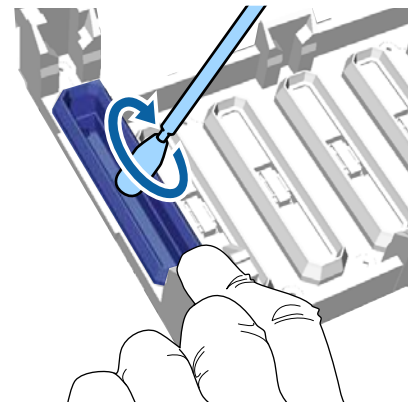

! Important:

Make sure ink cleaner does not drip onto the anti-drying caps. If any cleaner does drip, wipe it with a dry cleaning stick. If cleaner is left on the anti-drying caps, the print head nozzles could become clogged.

Maintenance

- 8** Wipe the outside of the suction cap with a wide cleaning stick.

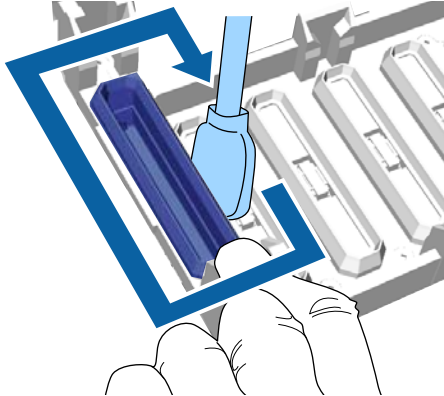

- 9** When wiping the outside of the suction cap, remember to also wipe the top edge.

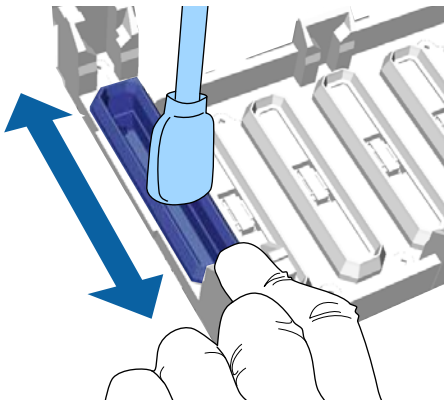

After removing ink from the cap as shown below, go to the next step.

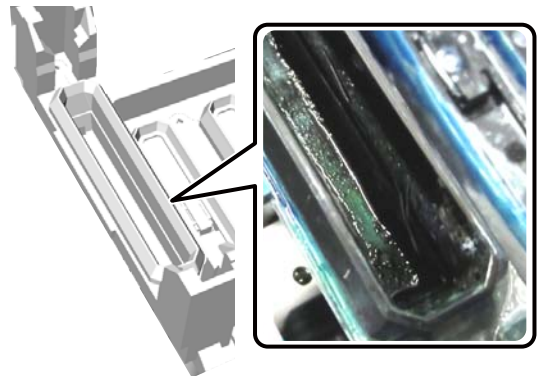
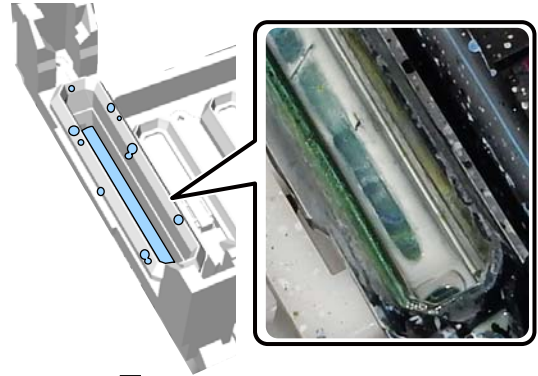

- 10** Close the printer cover, and then press the OK button.

When the print head returns to its normal position, the Settings menu closes. After you finish cleaning, we recommend checking for clogged nozzles.

[🔗 “Checking for clogged nozzles” on page 38](#)

Disposing of Used Consumables [🔗 “Disposal” on page 33](#)

Cleaning the scale and replacing the filter

When cleaning the scale and replacing the air filter, the message **See manual to clean scale and change air filter.** is displayed on the control panel. Clean the scale and then replace the air filter. Prepare a new air filter.

 [“Options and Consumable Products” on page 50](#)

Before starting this procedure, be sure to read the following:

 [“Cautions when operating” on page 31](#)

You can check the procedure in a video on YouTube.

[Epson Video Manuals](#)

1 Turn off the printer and check that the displayed screen disappears.

2 Open the printer cover.



3 Let the ink cleaner soak into the cleaning cloth (one) supplied with the new air filter.

 [“Using ink cleaner” on page 32](#)

4 Use the cleaning cloth soaked in ink cleaner to wipe away ink that has stuck to the scale.

Important:

Do not touch the carriage shaft inside the printer. It may cause an operational error or a malfunction.

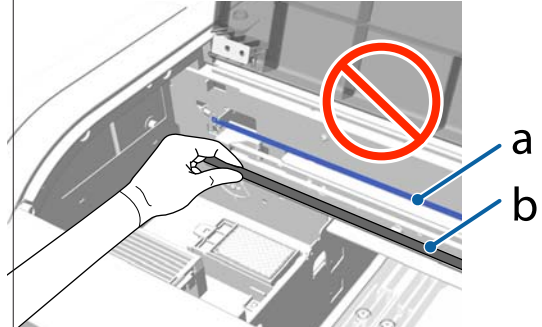

a: Scale

b: Carriage shaft

(1) Hold down the scale on the left-hand side.

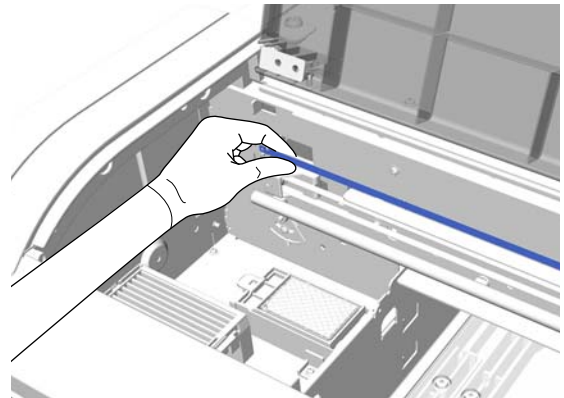

(2) Move the cleaning cloth in approximately 5 cm motions to the right and left to wipe away ink as you slowly move the cloth to the right-hand side.

You do not need to clean sections covered by the print head.

Maintenance

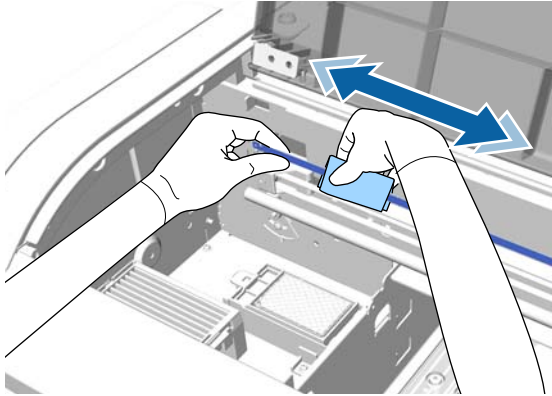

! **Important:**

❑ Do not pull the scale with excessive force. If it is pulled with too much force, the right section may detach.

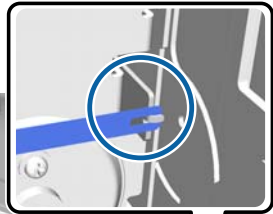

❑ Make sure that ink cleaner does not drip into the printer. If any cleaner does drip, wipe it with a dry cleaning cloth.

❑ Do not use anything except for the cleaning cloth supplied with the air filter.

❑ Do not rub the scale too hard. If it is damaged, the printer may not operate correctly.

5 Use a dry cleaning cloth to wipe away any ink cleaner or dust stuck to the scale.

6 Grip the tab on the air filter and remove it.

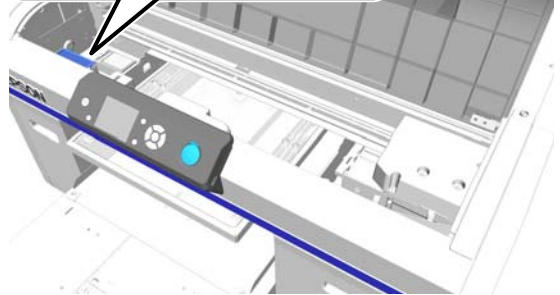
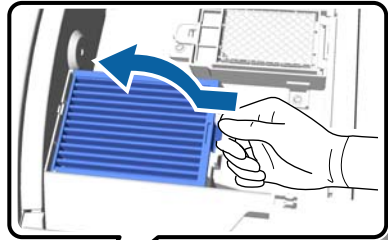

7 Put the old air filter into the bag of the new air filter.

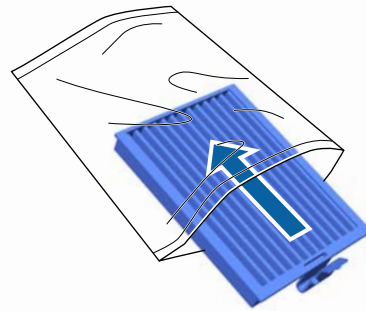

8 Attach the new air filter.

Insert the two teeth at the end of the filter into the holes in the printer, and then press down until you hear the tab click into place.

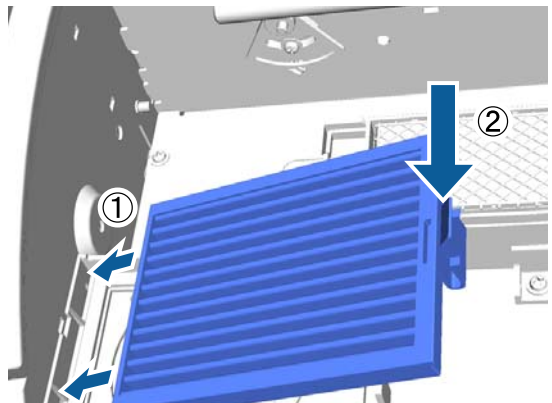

9 Close the printer cover.

Disposing of Used Consumables  [“Disposal” on page 33](#)

Checking for clogged nozzles

This section explains how to check nozzles when using the L, M, S, and XS size platens.

See the User's Guide for details on checking nozzles for the sleeve platen and the medium grooved platen.

 [User's Guide \(Online Manual\)](#)

Print a nozzle check pattern to check if the nozzles are clogged.

You need the following media to print the nozzle check pattern. The type of media to be used varies depending on the color mode setting.

Size

L, M, S size platens: A4 or letter size

XS size platen: 180 x 200 mm

Media type

White ink mode: Transparent media such as OHP film or colored paper

Color ink mode or high-speed color mode: Plain paper

Attach the media to the platen before printing. See the following for information on loading media.

Loading media

Buttons that are used in the following operations

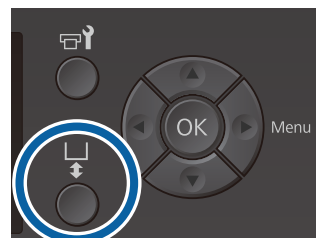

1

Check that the platen is ejected forward.

If it is not ejected, press the  button to move the platen forward.

Maintenance

- 2** Check that the platen is installed, and install the spacers in the following status.

L, M, S, and XS size platens

Attach spacers a and b.

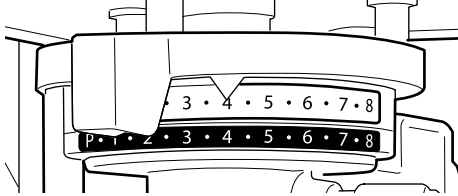

[“Replacing Platens and Removing/Attaching Spacers” on page 17](#)

- 3** Remove the frame if you are using a platen frame.

- 4** Load the media on the platen.

When L, M, S, and XS size platens are installed

Place in the center of the platen.

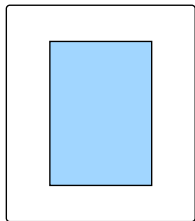

Make sure you place the media in the position shown above. If it is placed in a different position, the platen may be soiled with ink.

- 5** Secure the media with cellophane tape and so on to keep it in place.

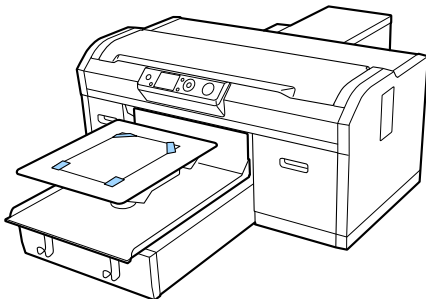

- 6** Set the platen gap adjustment lever to the following position on the scale.

- When a grip pad covered platen is installed: 1

- When a platen without fabric is installed: P

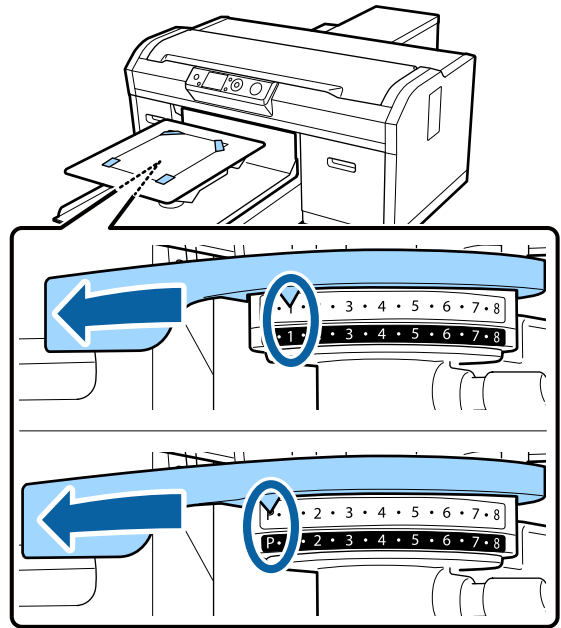

Printing a Nozzle Check Pattern

This section explains how to print a nozzle check pattern from the printer.

When the L, M, S, or XS size platens are installed, or the medium grooved platen is installed, you can print a nozzle check pattern from the printer or from the Garment Creator software supplied.

For the procedure for printing the nozzle check pattern from Garment Creator, see the Garment Creator's online help.

Buttons that are used in the following operations

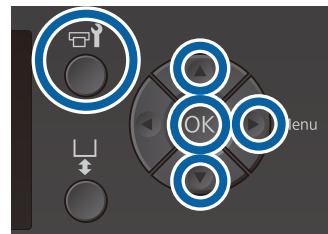

- 1** Press the button.
The Maintenance menu is displayed.

- 2** Press the buttons to highlight **Nozzle Check**, and then press the button.

Maintenance

3

Press the OK button.

4

Check that media is loaded, and then press the OK button again.

The nozzle check pattern is printed.

5

Check the nozzle check pattern.

Because the Cleaning liquid rows are difficult to see in color ink mode, it does not need to be checked.

Example of clean nozzles

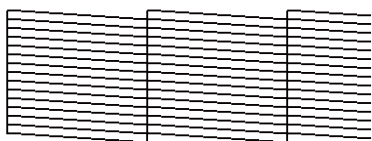

There are no gaps in the check pattern.

Example of clogged nozzles



Perform head cleaning when there are gaps in the nozzle check pattern.

 [“Cleaning the print head” on page 40](#)

Cleaning the print head

If the printed result is faint or has gaps, cleaning the print head may clear the clogged nozzles.

Head cleaning levels

You can select from three levels of head cleaning. Use light or medium for normal cleaning. Use heavy cleaning if you could not clear the clogged nozzle after cleaning with light or medium several times.

For several times after the initial ink charging, the amount of ink consumed is higher than normal as cleaning is performed in the same way as for initial ink charging, regardless of the selected level.

Note:

The automatic cleaning start time displayed on the control panel screen may be reset, depending on the selected cleaning level.

Auto maintenance function

This printer has a convenient built-in auto maintenance function (Power On Cleaning) that performs head cleaning after turning on the printer and before printing.

 [User's Guide \(Online Manual\)](#)

Notes on head cleaning

- Clean the print head only if print quality declines; for example, if text is faint, or images are in the incorrect colors. Ink is consumed when head cleaning is performed.
- Head cleaning all nozzles consumes ink for all colors.

Cleaning the print head

This section explains how to clean the print head after you have confirmed clogged nozzles from the check pattern.

Maintenance

Buttons that are used in the following operations

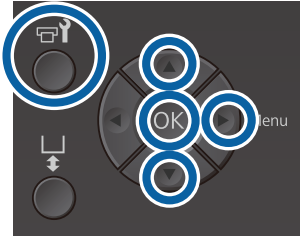

- 1 Press the  button.
The Maintenance menu is displayed.
- 2 Press the ▲/▼ buttons to highlight **Head Cleaning**, and then press the ► button.
- 3 Press the ▲/▼ buttons to highlight the method for cleaning the nozzle row, and then press the ► button.

Selected Nozzles

Select this option when you have observed faint or missing parts in a specific pattern (nozzle row) in the check pattern. You can select multiple nozzle rows.

All Nozzles

Select this option when you have observed faint or missing parts in all patterns. Go to step 5 after selecting **All Nozzles**.

- 4 Select nozzle rows for cleaning.
 - Press the ▲/▼ buttons to highlight the number corresponding to the check pattern that contains faint or missing parts, and then press the OK button.
 - When you have selected all of the nozzle rows you want to clean, press the ► button.
- 5 Press the ▲/▼ buttons to highlight the cleaning level, and then press the OK button.
Head cleaning is executed.
When head cleaning is complete, the Settings menu closes.

Print a check pattern and confirm that the nozzles have been cleared.

 [“Checking for clogged nozzles” on page 38](#)

Nozzles are still clogged after performing head cleaning several times

The edge of the metal may be soiled.
Perform the following.

Clean edges of the metal  [User's Guide \(Online Manual\)](#)

Shaking and Replacing Ink Cartridges

Shaking

Timing and frequency of shaking

Important:

Due to ink characteristics, the ink cartridges of this printer are prone to sedimentation (components settling to the bottom of the liquid). If ink settles, tint unevenness and nozzle clogs occur.

Shake a new ink cartridge before installing it. After installing it in the printer, remove and shake it periodically.

You do not need to shake the Cleaning cartridges.

- When replacing Remove the new cartridge from the package, and shake thoroughly. The number of shakes depends on the ink color.

White ink	Approx. 50 times on each side (for approx. 15 seconds)
Color Ink	Approx. 15 times (for approx. 5 seconds)

- Before starting printing operations for the day (White only) White ink tends to settle more than other colors. If you turn on the printer every day, remove the ink cartridge, and then shake it the number of times listed below. If ink cartridges have not been shaken for 20 hours or more, and the message **Remove and shake WH ink** is displayed. If the message appears, remove the ink cartridge immediately, and then shake it.

Approx. 25 times on each side (for approx. 8 seconds)

- Once a month (color ink) Even after installing an ink cartridge in the printer, remove and shake it periodically.

Approx. 15 times (for approx. 5 seconds)

Shaking method

- Make sure the printer is on, and then remove the ink cartridge. When replacing a cartridge, remove the new one from the bag.
- Shake the cartridge horizontally thoroughly in 5 cm movements.

Color Ink

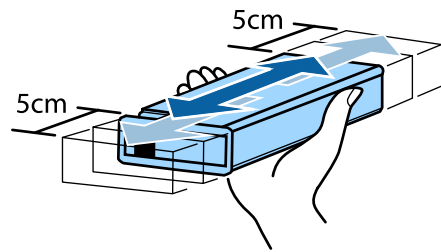

White ink

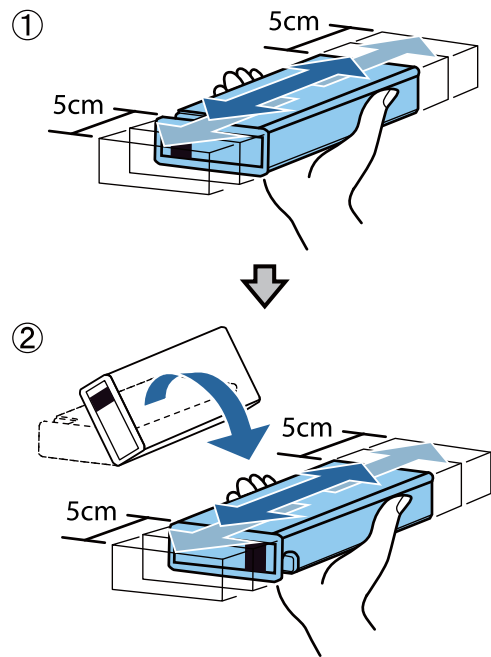

Replacement procedure

When the message **Ink Low** is displayed on the screen, replace the ink cartridge as soon as possible. If one of the installed ink cartridges is expended, printing cannot be performed.

If an ink cartridge is expended while printing, you can continue printing after replacing the ink cartridge. However, if the ink cartridge is replaced during a print job, the tone of the print results may differ depending on the drying conditions.

Maintenance

The following procedure explains how to replace ink cartridges and the Cleaning cartridge.

! Important:

Epson recommends the use of genuine Epson ink cartridges. Epson cannot guarantee the quality or reliability of non-genuine ink. The use of non-genuine ink may cause damage that is not covered by Epson's warranties, and under certain circumstances, may cause erratic printer behavior. Information about non-genuine ink levels may not be displayed, and use of non-genuine ink is recorded for possible use in service support.

1 Make sure the printer is on.

2 Open the cartridge cover.

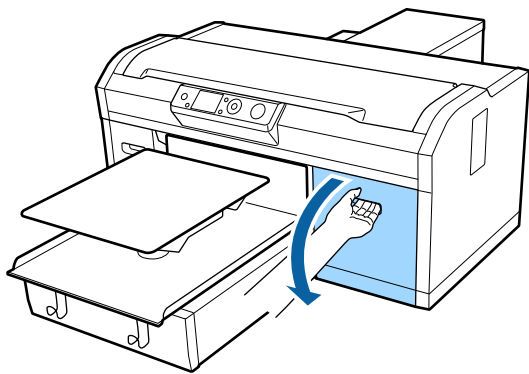

3 Put your finger into the indentation on top of the ink cartridge to be replaced, and pull it straight out.

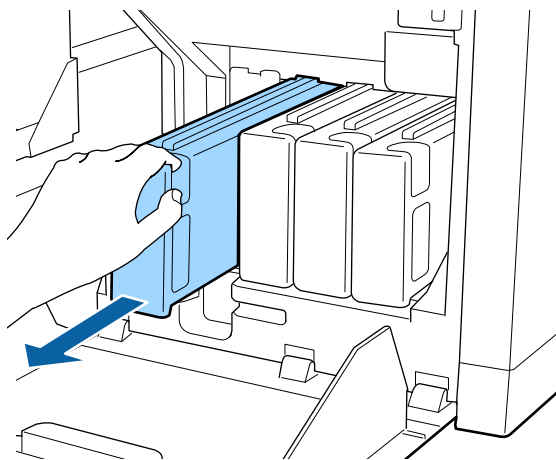

! Important:

Do not touch the IC chip on the top of the ink cartridge. The cartridge may not be recognized, or the printer may become unable to print properly.

4 Hold the cartridge horizontally and shake it in both directions about 5 cm 15 times in 5 seconds. Shake White ink well on both sides approx. 50 times in 15 seconds.

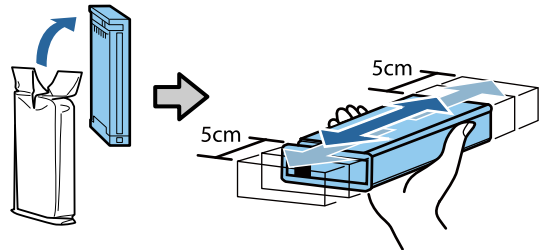

5 Match the color of the cartridge to the color of the label on the printer and insert.

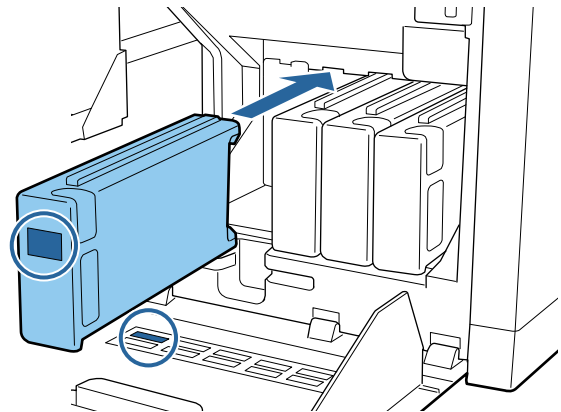

Repeat Steps 3 to 5 to replace other ink cartridges.

! Important:

Install ink cartridges into all slots. The printer cannot print unless ink cartridges are installed in all slots.

6

Close the cartridge cover.

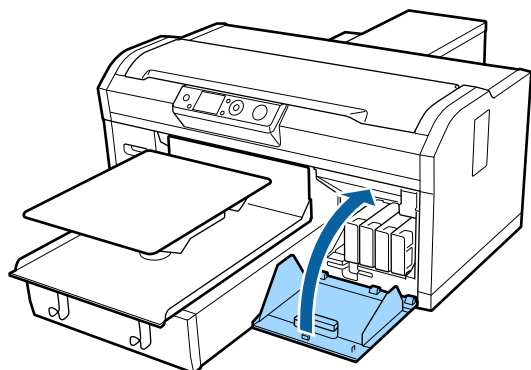

Disposal  [“Disposal of used consumables” on page 33](#)

Disposing of Waste Ink

Preparing and Replacement Timing

When Prepare empty waste ink bottle. is displayed

Prepare a new Waste Ink Bottle as soon as possible. When you want to replace the Waste Ink Bottle at this stage due to night operations and so on, select Waste Ink Counter from the maintenance menu, and then replace the bottle. If you perform the replacement without selecting Waste Ink Counter, the waste ink counter will not operate correctly.

Details on the setup menu  [User's Guide \(Online Manual\)](#)

Waste Ink Counter  [“Waste Ink Counter” on page 44](#)

Important:

Never remove the waste ink bottle while printing or carrying out the following maintenance procedures. Waste ink may leak.

- Tube Washing
- Head Cleaning
- Replace White Ink
- Pre-Storage Maint.

If you follow the message instructions (Replace waste ink bottle and press .) is displayed

Replace the Waste Ink Bottle with a new bottle immediately.

Replacement procedure  [“Replacing the waste ink bottle” on page 45](#)

Waste Ink Counter

The printer uses the waste ink counter to track waste ink and displays a message when the counter reaches the warning level. If you follow the message instructions **Replace waste ink bottle and press  .** and replace the Waste Ink Bottle with a new one, the counter is cleared automatically.

Maintenance

If you need to replace the waste ink bottle before the message is displayed, select Waste Ink Counter from the maintenance menu.

 *User's Guide* (Online Manual)

! Important:

Always clear the waste ink counter if you replace the Waste Ink Bottle before being prompted to do so by a message. Otherwise, the replacement interval for the Waste Ink Bottle will no longer be measured correctly.

Replacing the waste ink bottle

Before starting this procedure, be sure to read the following:

 "Cautions when operating" on page 31

- 1** Remove the outer and inner caps from the new waste ink bottle.

! Important:

You need the caps when disposing of the waste ink bottle. Keep them in a safe place.

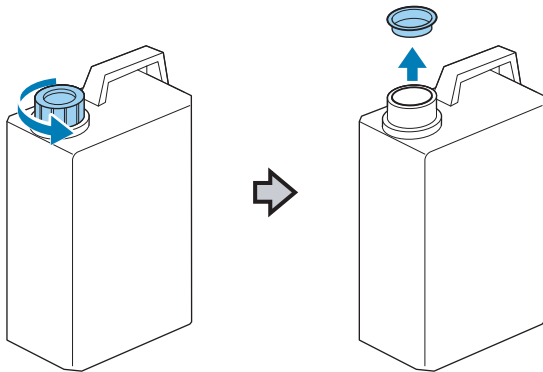

- 2** Remove the waste ink tube from the used waste ink bottle, and insert it into the new waste ink bottle taking care not to spill any waste ink.

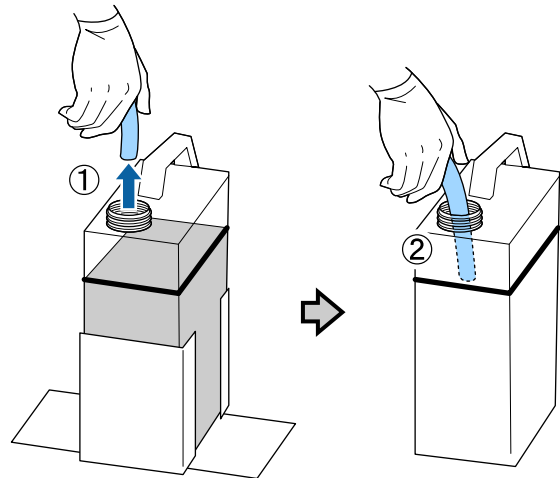

- 3** Place the caps onto the used waste ink bottle.

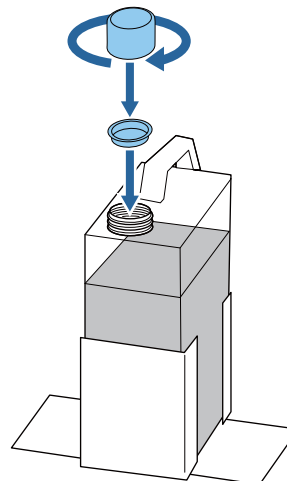

- 4** Remove the used waste ink bottle from the waste ink bottle holder, and then place the new bottle.

! Important:

Make sure that the waste ink tube is inserted into the neck of the bottle. If the waste ink tube comes out of the bottle, waste ink will spill out.

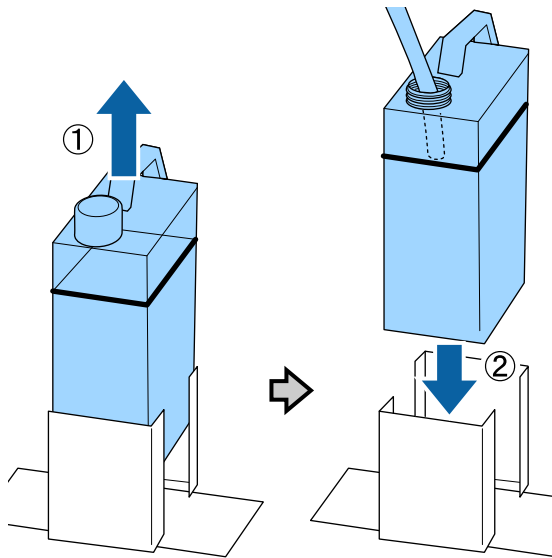

- 5** Press the OK button.
- 6** Check again to confirm that a new Waste Ink Bottle is correctly placed. Press the OK button to clear the waste ink counter.

Dispose of the waste ink with the waste ink bottle. Do not pour it into another container.

! Important:

Note the following points when transferring waste ink from the waste ink bottle to another container.

- Use a container made of PE (polyethylene) when transferring the waste ink.
- Attach the spout included with the printer to the rim of the waste ink bottle and transfer the waste ink.
- Pour the waste ink carefully. Pouring the waste ink quickly may cause it to spill and splatter.
- Store the waste ink by securely closing the lid of the container to which you transferred it.

Disposing of used waste ink and Waste Ink Bottles [☞](#) “Disposal” on page 33

Replacing the Head Cleaning Set

Preparing and Replacement Timing

When Head cleaning set is nearing end of life, is displayed

Prepare a new head cleaning set as soon as possible.

When you want to replace the parts at this stage, implement **Head Cleaning Set** from the setup menu, and then replace the parts. If you replace them without implementing **Head Cleaning Set**, the head cleaning set counter will not operate correctly.

Details on the setup menu [☞](#) *User's Guide* (Online Manual)

! Important:

About the Head Cleaning Set Counter

The printer tracks amounts consumed using the head cleaning set counter and displays a message when the counter reaches the warning level.

If you replace parts when the message “**✖ Head Cleaning Set Life**” is displayed, the counter is cleared automatically.

If you need to replace the parts before the message is displayed, implement **Head Cleaning Set** from the setup menu.

Details on the setup menu [☞](#) *User's Guide* (Online Manual)

When **✖ Head Cleaning Set Life** is displayed

See the following page, and replace all the parts included in the head cleaning set. Printing cannot be performed if the parts are not replaced.

The head cleaning sets contains the following parts.

- Wiper unit (x1)
- Anti-drying cap (x1)

Maintenance

- ❑ Flushing pad (x1)

Always choose a replacement head cleaning set that is specified for this printer.

📖 “Options and Consumable Products” on page 50

Before starting this procedure, be sure to read the following:

📖 “Cautions when operating” on page 31

How to Replace the Head Cleaning Set

- 1 Press the OK button in the  **Head Cleaning Set Life** screen.

The platen and print head move to the maintenance position.

Note:

After 10 minutes from the start of replacing the head cleaning set, a screen will be displayed and a buzzer sounds informing you that 10 minutes have elapsed. Press the OK button to continue the replacement process. After 10 more minutes have passed, the buzzer sounds again.

If the print head is moved out of its home position for more than 10 minutes, the nozzles could easily be clogged. Finish replacement as quickly as possible.

- 2 Open the printer cover.



- 3 Place your fingers in the groove on the back of the wiper unit, and tilt it forward a little.

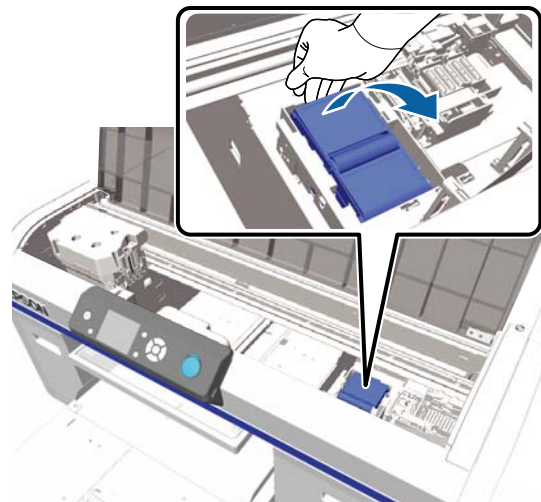

- 4 Grip the sides, and pull it straight up to lift it out.

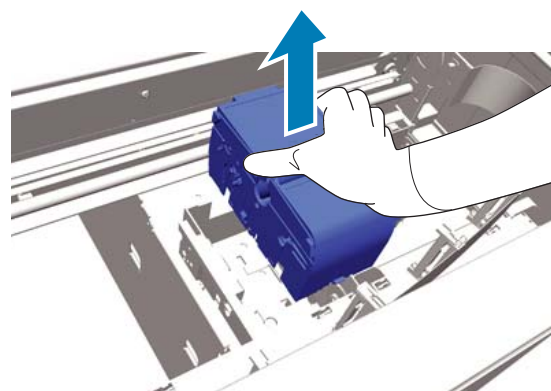

- 5 To avoid soiling your surroundings with ink, wrap the used wiper unit in the packaging supplied with the new wiper unit.

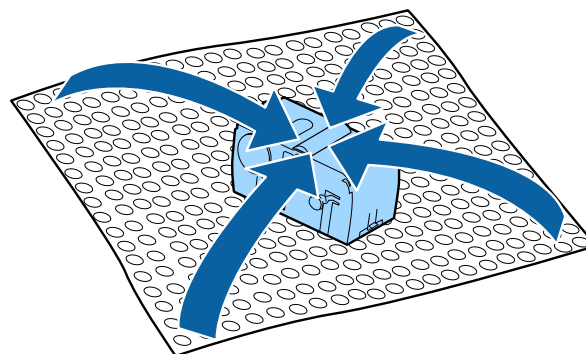

Maintenance

- 6** Insert the new wiper unit.
Place on the attachment point and press down until you hear a click.

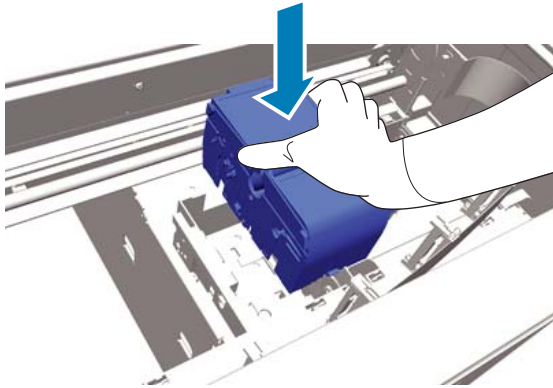

- 7** Unpack the new anti-drying cap, and then remove the cover.



- 8** Press the lever towards you, and then lift the anti-drying cap to remove it.

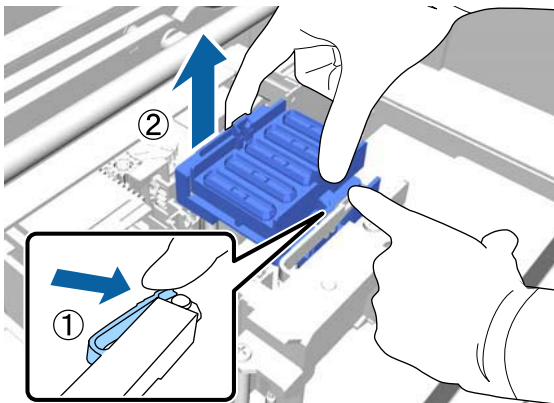

- 9** Attach the cover removed in step 7 to the old anti-drying cap, and then put it into the bag of the new anti-drying cap.

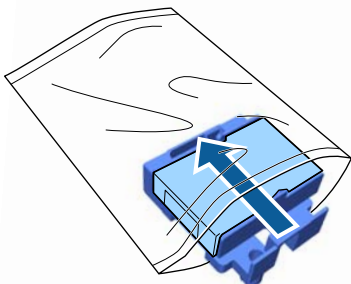

- 10** Press the lever forwards, and then place the holes in the anti-drying cap over the two poles on the printer.

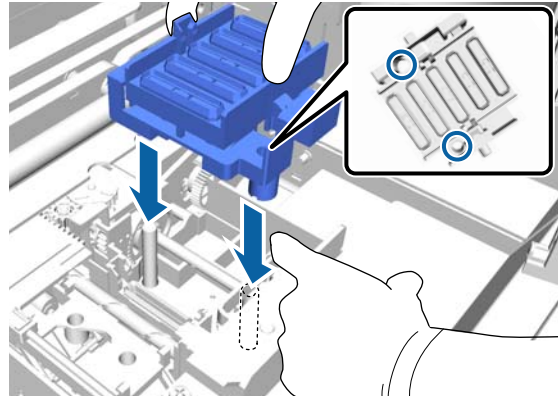

- 11** Close the printer cover, and then press the OK button.

- 12** Press the ▲/▼ buttons to highlight Yes, and then press the OK button.

Press the OK button to move the print head to the flushing pad replacement position.

- 13** Open the printer cover.

- 14** Lift up the tab on the flushing pad, and remove it.

! **Important:**

Do this carefully as ink could spray out if it is raised with too much force.

Maintenance

Hold it at an angle and wait until the waste ink stops dripping from the flushing pad. Remove and place it on the metal tray.

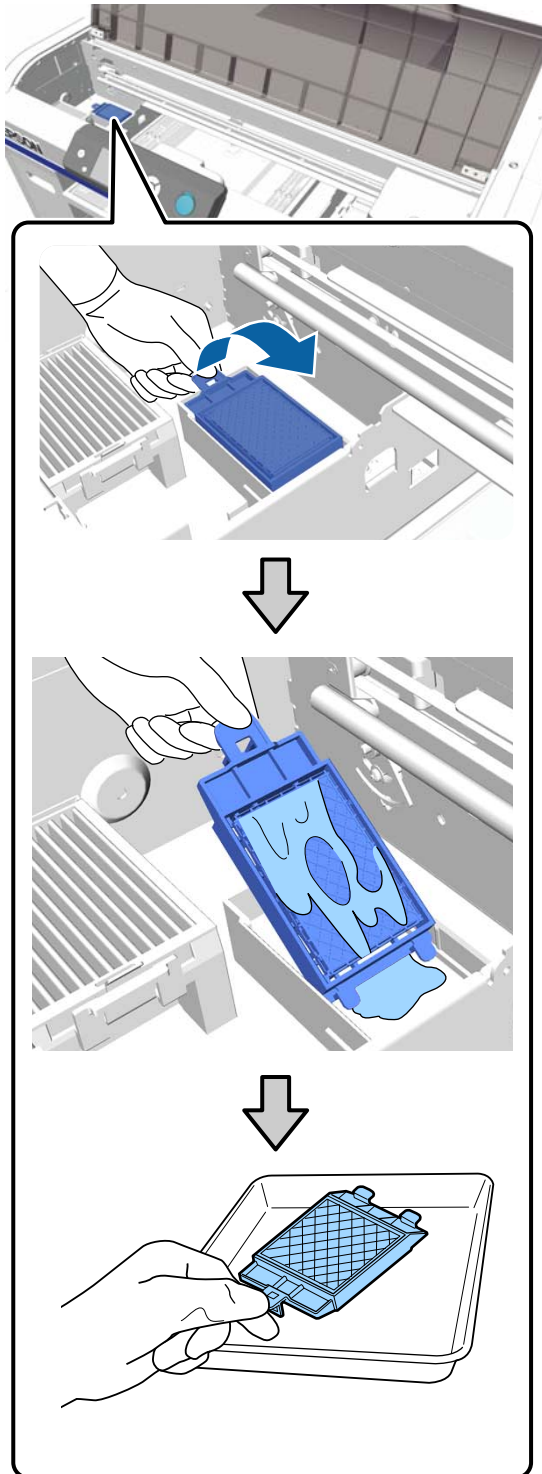

- 15 Place the removed flushing pad in the packaging that contained the new flushing pad.

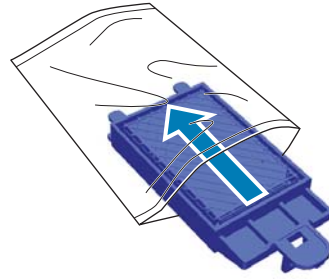

- 16 Insert the two hooks on the flushing pad into the slots on the printer and press the tab down until the pad clicks into place.

! Important:

If the hooks are not inserted correctly, the print head could be damaged.

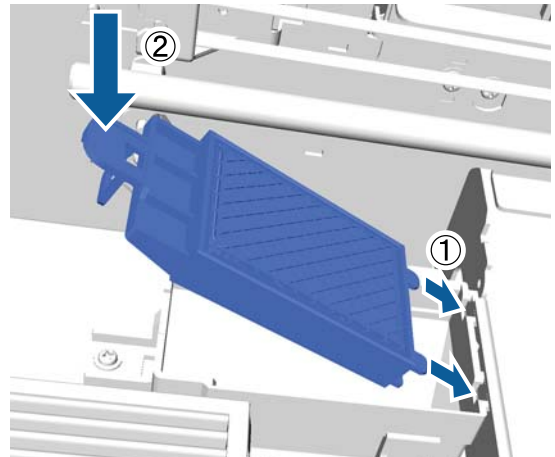

- 17 Close the printer cover, and then press the OK button.

The menu close.

Disposing of Used Consumables [“Disposal” on page 33](#)

Options and Consumable Products

The following options and consumable products are available for use with your printer. (As of December, 2017)

For the latest information, see the Epson Web site.

Ink cartridges*





Printer model	Product name		Product number
SC-F2100 SC-F2130 SC-F2160	Ink cartridges (600 ml)	Black	T7251
		Cyan	T7252
		Magenta	T7253
		Yellow	T7254
		White	T725A
	Ink cartridges (250 ml)	Black	T7301
		Cyan	T7302
		Magenta	T7303
		Yellow	T7304
		White	T730A
SC-F2180	Ink cartridges (600 ml)	Black	T7261
		Cyan	T7262
		Magenta	T7263
		Yellow	T7264
		White	T726A
	Ink cartridges (250 ml)	Black	T7311
		Cyan	T7312
		Magenta	T7313
		Yellow	T7314
		White	T731A

* Epson recommends the use of genuine Epson ink cartridges. Epson cannot guarantee the quality or reliability of non-genuine ink. The use of non-genuine ink may cause damage that is not covered by Epson's warranties, and under certain circumstances, may cause erratic printer behavior. Information about non-genuine ink levels may not be displayed, and use of non-genuine ink is recorded for possible use in service support.

 ["Shaking and Replacing Ink Cartridges" on page 42](#)

Options and Consumable Products

Others

Product name	Product number	Explanation
Cleaning cartridge	T7360	For washing the print head and washing the tubes.
Pre-treatment Liquid	T7361	20 liters. Dilute before use.  User's Guide (Online Manual)
Maintenance Kit	T7362	The same as the maintenance kit supplied with the printer. This set contains gloves, cleaning sticks, ink cleaner, and a cup for performing regular maintenance operations such as cap cleaning.  "Maintenance" on page 27
Head Cleaning Set	C13S092001	This set contains a flushing pad and wiper unit.  "Cleaning the print head" on page 40
Air Filter	C13S092021	Set of air filter and cleaning cloths (x5).  "Cleaning the scale and replacing the filter" on page 36
Waste Ink Bottle	T7240	The same as the waste ink bottle supplied with the printer.
Large Platen (16" x 20"/406 x 508 mm) (except for SC-F2180)	C12C933921	External dimensions: (W) 439 x (D) 541 x (H) 52 mm, Weight: 3.7 kg, Platen thickness: 8 mm
Large Platen (16" x 20"/406 x 508 mm) (for SC-F2180)	C12C933981	
Medium Platen (14" x 16"/356 x 406 mm) (except for SC-F2180)	C12C933931	The same as the platen supplied with the printer. External dimensions: (W) 389 x (D) 439 x (H) 50 mm, Weight: 2.6 kg, Platen thickness: 8 mm
Medium Platen (14" x 16"/356 x 406 mm) (for SC-F2180)	C12C933991	
Small Platen (10" x 12"/254 x 305 mm) (except for SC-F2180)	C12C933941	External dimensions: (W) 287 x (D) 338 x (H) 50 mm, Weight: 1.7 kg, Platen thickness: 8 mm
Small Platen (10" x 12"/254 x 305 mm) (for SC-F2180)	C12C934001	
Extra Small Platen (7 "x 8 " / 178 x 203 mm) (except for SC-F2180)	C12C933951	External dimensions: (W) 209 x (D) 234 x (H) 40 mm, Weight: 1.0 kg
Extra Small Platen (7 "x 8 " / 178 x 203 mm) (for SC-F2180)	C12C934011	
Sleeve Platen (except for SC-F2180)	C12C933971	External dimensions: (W) 147 x (D) 379 x (H) 46mm, Weight: 0.9 kg
Sleeve Platen (for SC-F2180)	C12C934031	
Medium Grooved Platen (except for SC-F2180)	C12C933961	External dimensions: (W) 389 x (D) 439 x (H) 50 mm (same as M-size platen), Weight: 3.8 kg
Medium Grooved Platen (for SC-F2180)	C12C934021	

Options and Consumable Products

Product name	Product number	Explanation
Platen Grip Pad - L (except for SC-F2180)	C13S210075	A grip pad for using the L-size platen as a grip pad covered platen.
Platen Grip Pad - L (for SC-F2180)	C13S210078	
Platen Grip Pad - M (except for SC-F2180)	C13S210076	The same as the grip pad supplied with the printer. A grip pad for using the M-size platen as a grip pad covered platen.
Platen Grip Pad - M (for SC-F2180)	C13S210079	
Platen Grip Pad - S (except for SC-F2180)	C13S210077	A grip pad for using the S-size platen as a grip pad covered platen.
Platen Grip Pad - S (for SC-F2180)	C13S210080	
Pre-treatment roller set	C12C891201	Set of roller x3, handle, and tray.
Replacement rollers for pre-treatment (3 pieces)	C12C891211	The same as the roller supplied with the Pre-treatment roller set.
Hard roller	C12C891221	Set of roller (hard) and handle.
Grip Pad Tool (except for SC-F2180)	C12C934151	The same as the grip pad tool supplied with the printer.
Grip Pad Tool (for SC-F2180)	C12C934161	