

SMALL SMD HIGH - FREQUENCY CRYSTAL UNIT

MA-306

- High-density mounting-type SMD.
- Excellent reliability and environment capability.
- Capable of covering a wide frequency range. (from 17.734 MHz to 41 MHz)
- 2.54mm thickness is equal to SMD-type IC.

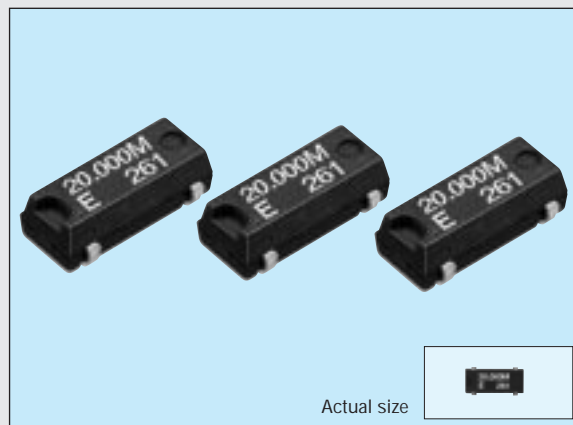

Specifications (characteristics)

Item	Symbol	Specifications	Remarks	
Nominal frequency	f	17.734 MHz to 41.000 MHz	Fundamental mode	
Temperature range	Storage temperature	T _{STG}	-55°C to +100°C	Stored as bare product after unpacking
	Operating temperature	T _{OPR}	-20°C to +70°C	
Drive level	Maximum drive level	GL	2mW max.	Only crystal oscillation is guaranteed
	Recommended drive level	DL	10μW to 100μW	
Soldering condition	T _{SOL}	Twice at under 260°C within 10 sec. or under 230°C within 3 min.		
Frequency tolerance (standard)	Δf/f	±50ppm	T _a =25°C±3°C	
Frequency temperature characteristics (standard)		±30ppm	-20°C to +70°C	
Load capacitance	C _L	10pF to ∞	Please specify	
Series resistance	R ₁	60 Ω max.	-20°C to +70°C, DL=100μW	
Shunt capacitance	C ₀	5pF max.		
Insulation resistance	IR	500 MΩ min.		
Aging	f _a	±5ppm/Y max.	T _a =25°C±3°C, first year	
Shock resistance	S.R.	±10ppm max.	Three drops on a hard board from 75 cm or excitation test with 3000G x 0.3ms x 1/2 sine wave x 3 directions	

There are some cases that a parts of the cylindrical capsule of quartz unit expose on the surface of the molding material.

External dimensions

(Unit: mm)

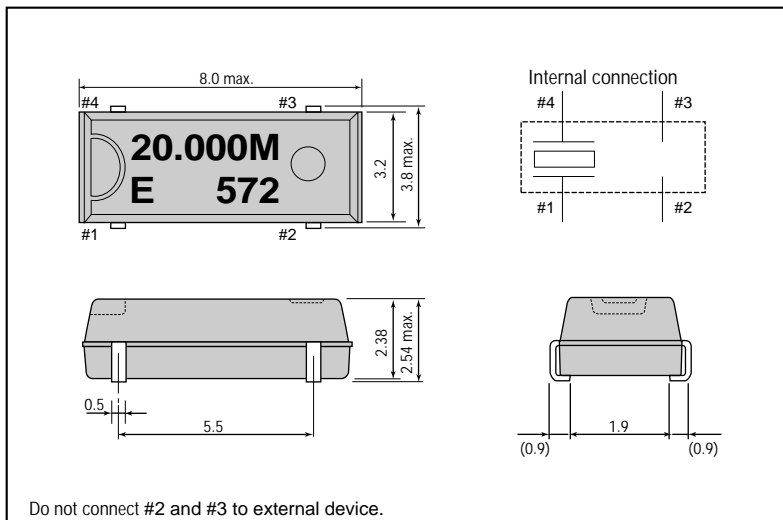

Recommended soldering pattern

(Unit: mm)

