

SMALL SMD LOW / MEDIUM-FREQUENCY
CRYSTAL UNIT

MC-306

- High-density mounting-type SMD.
- Photolithography finished allows uniform and stable performance.
- Excellent reliability and environmental capability.
- 2.54mm thickness is equal to SMD-type IC.

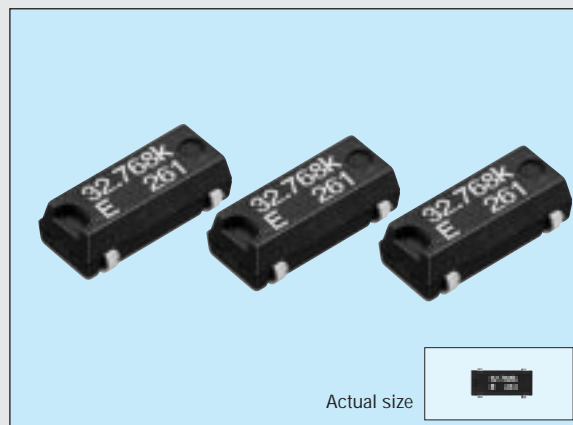

■ Specifications (characteristics)

Item	Symbol	Specifications		Remarks
Nominal frequency	f	32.768 kHz	20.000 kHz to 165.000 kHz	
Temperature range	Storage temperature	T _{STG} -55°C to +125°C		Stored as bare product after unpacking
	Operating temperature	T _{OPR} -40°C to +85°C		
Maximum drive level	GL	1.0μW max.		
Soldering condition	T _{SOL}	Twice at under 260°C within 10 sec. or under 230°C within 3 min.		
Frequency tolerance (standard)	Δf/f	±20ppm, ±50ppm	±50ppm, ±100ppm	T _a =25°C, DL=0.1μW
Peak temperature (frequency)	θT	25°C ±5°C		
Temperature coefficient (frequency)	a	-0.04ppm/°C ² max.		
Load capacitance	C _L	6pF to ∞		Please specify
Series resistance	R ₁	50 kΩ max.	55 kΩ to 10 kΩ	As per below table
Motional capacitance	C ₁	1.8fF typ.	4.0fF to 0.6fF	
Shunt capacitance	C ₀	0.9pF typ.	2.0pF to 0.6pF	
Insulation resistance	IR	500 MΩ min.		
Aging	f _a	±3ppm/Y max.	±5ppm/Y max.	T _a =25°C ±3°C, first year
Shock resistance	S.R.	±5ppm max.		Three drops on a hard board from 75 cm or excitation test with 3000G x 0.3ms x 1/2 sine wave x 3 directions

There are some cases that a parts of the cylindrical capsule of quartz unit expose on the surface of the molding material.

■ Series resistance

Frequency (kHz)	20 ≤ f < 30	30 ≤ f < 40	40 ≤ f < 60	60 ≤ f < 70	70 ≤ f < 120	120 ≤ f < 165
Series resonance resistance (Ω)	55K Ω max.	45K Ω max.	20K Ω max.	15K Ω max.	12K Ω max.	10K Ω max.

■ External dimensions

(Unit: mm)

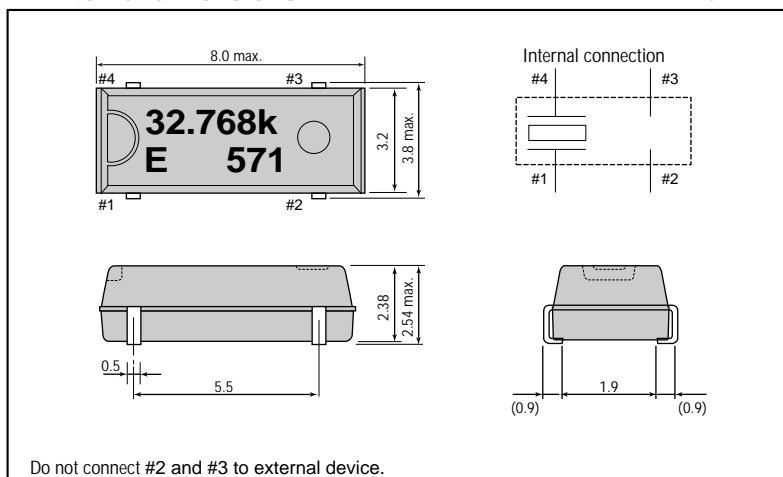

■ Recommended soldering pattern

(Unit: mm)

